

REV.	ECN NO OR DESCRIPTION	REVISED	DATE
A	PDR NO:T181123-4A	PAN	2019.11.26
B	ECN NO:S202006-C33	PAN	2021.01.11

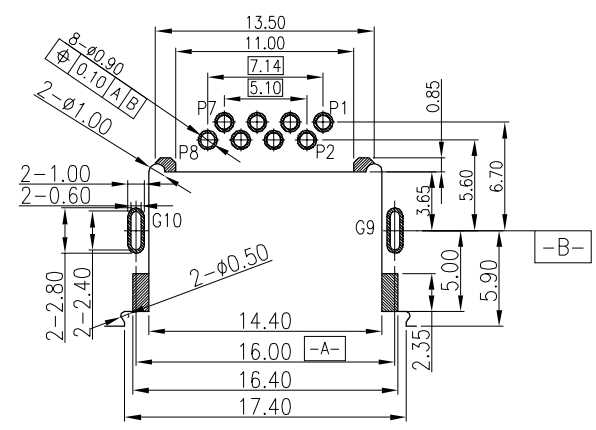
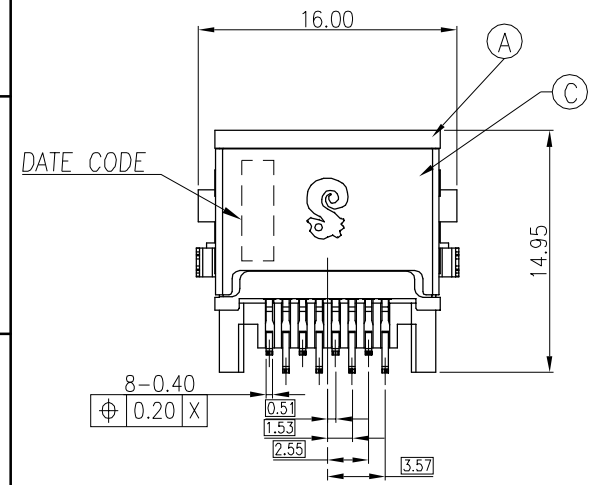
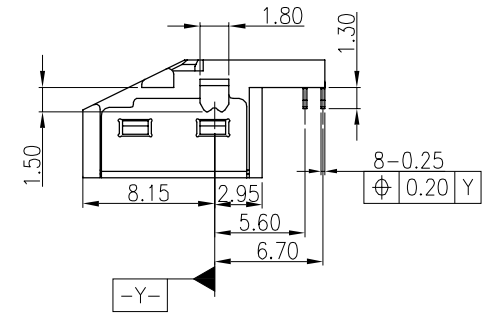
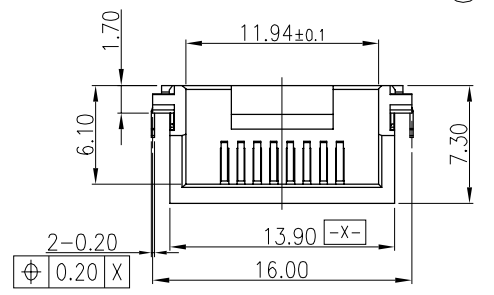
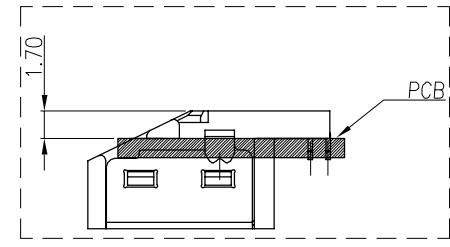
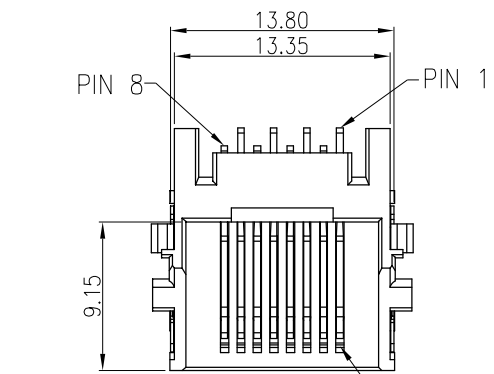

RECOMMENDED PCB LAYOUT  
TOP VIEW ; TOL.±0.05  
(PCB THICKNESS=1.20mm)

SPECIFICATIONS:

- ELECTRICAL CHARACTERISTICS:
  - CURRENT RATING: 0.5A MAX.
  - VOLTAGE RATING: 150V MAX.
  - CONTACT RESISTANCE : 50mΩ MAX.(INITIAL).  
100mΩ MAX.(AFTER LIFE TEST).
  - INSULATION RESISTANCE : 100MΩ MIN.
- MECHANICAL CHARACTERISTICS:
  - DURABILITY: 5000 CYCLES.
  - INSERTION FORCE: 2.25Kg MAX. WITH LATCH DEPRESSED.
  - WITHDRAWAL FORCE: 4.5Kg MAX. WITH LATCH DEPRESSED.
  - OPERATING TEMPERATURE: -30℃ ~ +70℃.
- MARKING: MARK "S" INSIDE OF THE CONNECTOR.
- PACKAGING : TAPE & REEL.
- TO CONFORM TO SINGATRON HAZARDOUS SUBSTANCE FREE SPEC.
- HALOGEN FREE PRODUCT IDENTIFICATION  
MARK ON PRODUCT: S
- HALOGEN FREE PRODUCT IDENTIFICATION LOGO  
ON THE PACKAGING: S
- FOR REFLOW SOLDERING LEAD-FREE PROCESS.
- PRINTED DATE CODE" YY MM DD " ON TOP OF THE CONNECTOR.  
DD: DAY  
MM: MONTH  
YY: YEAR

D	COVER	1	HIGH TEMP.THERMOPLASTIC	UL 94V-0 & BLACK
C	SHELL	1	STAINLESS STEEL	NI PLATING ALL OVER
B	8PCS CONTACT	8	PHOSPHOR BRONZE 0.25t	G/F AU ON CONTACT AREA; Matte Sn 120u" ON SOLDER TAIL; ALL OVER Ni 50u"MIN.
A	BODY	1	HIGH TEMP.THERMOPLASTIC	UL 94V-0 & BLACK
NO	DESCRIPTION	QTY	MATERIAL	PLATING & COLOR

UNLESS OTHERWISE SPECIFIED TOLERANCES

Singatron Enterprise Co., Ltd.  
信音企業股份有限公司

DECIMALS:	ANGLES:	TITLE	RJ45 JACK		
X : ±0.5	X : ±2°	DWN	PAN	PART NO. 2RJ3076-0D8211F	
X.X : ±0.3	X.X : ±1°	CHKD	ALLEN	SCALE 4:1	UNIT: mm
X.XX : ±0.2		APVD	BOYE	SIZE: A3	SHEET: 1 / 2
					REV: B
				CUSTOMER COPY	

REV.	ECN NO OR DESCRIPTION	REVISED	DATE
A	PDR NO:T181123-4A	PAN	2019.11.26
B	ECN NO:S202006-C33	PAN	2021.01.11

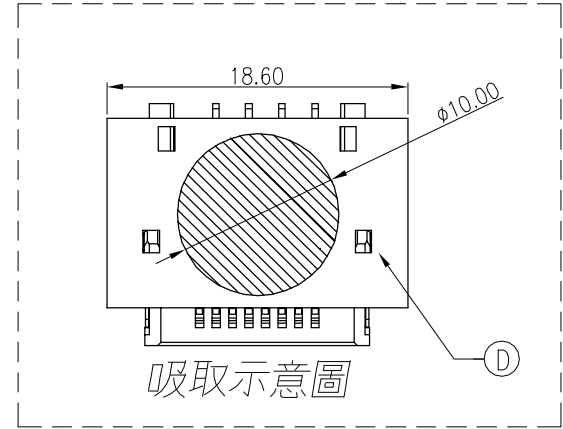
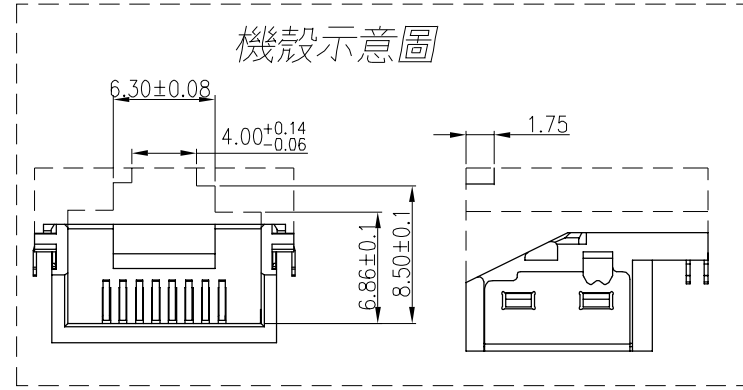
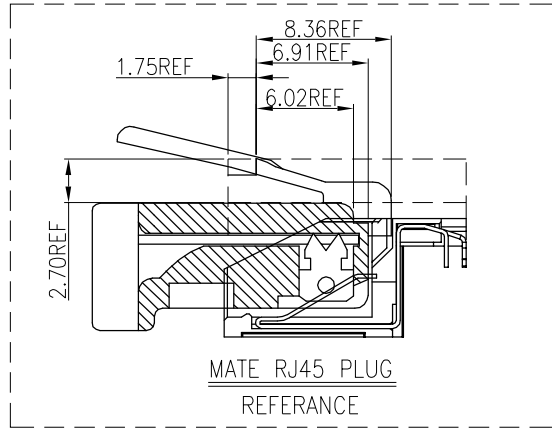

NO	DESCRIPTION	QTY	MATERIAL	PLATING & COLOR
UNLESS OTHERWISE SPECIFIED TOLERANCES			Singatron Enterprise Co., Ltd. 信音企業股份有限公司	
DECIMALS:		ANGLES:		
X	±0.5	X	±2°	
X.X	±0.3	X.X	±1°	
X.XX	±0.2			
TITLE		RJ45 JACK		
DWN	PAN	PART NO. 2RJ3076-0D8211F		
CHKD	ALLEN	SCALE 4:1	UNIT: mm	
APVD	BOYE	SIZE: A3	SHEET: 2/2	REV: B
CUSTOMER COPY				