

REV.	ECN NO OR DESCRIPTION	REVISED	DATE
A	PDR NO:T191127-2A	PAN	2020.03.12

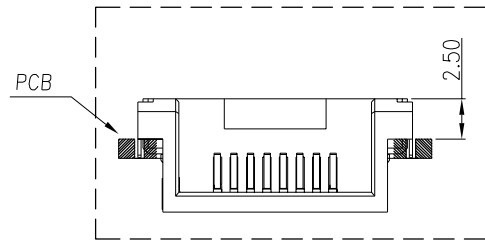
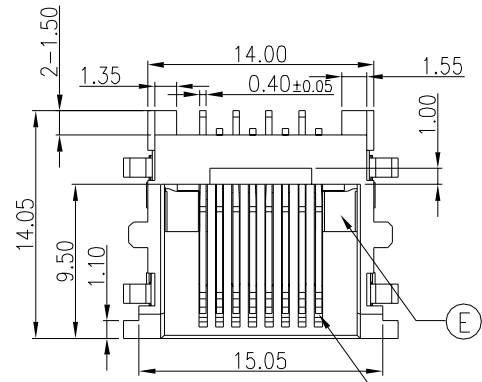

SPECIFICATIONS:

- ELECTRICAL CHARACTERISTICS:
 - CURRENT RATING: 0.5A MAX.
 - VOLTAGE RATING: 150V MAX.
 - CONTACT RESISTANCE : 50mΩ MAX.(INITIAL).
100mΩ MAX.(AFTER LIFE TEST).
 - INSULATION RESISTANCE: 100MΩ MIN.
- MECHANICAL CHARACTERISTICS:
 - DURABILITY: 5000 CYCLES.
 - INSERTION FORCE: 2.25Kg MAX. WITH LATCH DEPRESSED.
 - WITHDRAWAL FORCE: 4.5Kg MAX. WITH LATCH DEPRESSED.
 - OPERATING TEMPERATURE:-30℃ ~ +70℃
- MARKING: MARK "S" INSIDE OF THE CONNECTOR.
- PACKAGING : TAPE & REEL.
- TO CONFORM TO SINGATRON HAZARDOUS SUBSTANCE FREE SPEC.
- HALOGEN FREE PRODUCT IDENTIFICATION
MARK ON PRODUCT:
- HALOGEN FREE PRODUCT IDENTIFICATION LOGO
ON THE PACKAGING:
- FOR REFLOW SOLDERING LEAD-FREE PROCESS.
- PRINTED DATE CODE" YY MM DD " ON TOP OF THE CONNECTOR.

DD: DAY
MM: MONTH
YY: YEAR

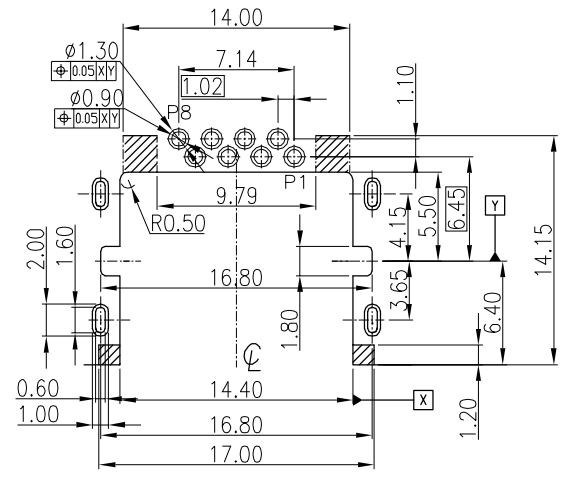
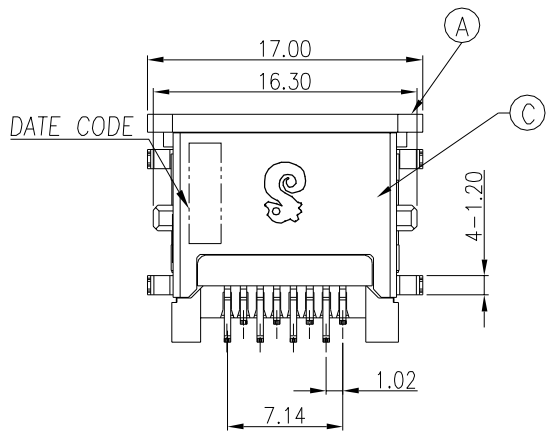
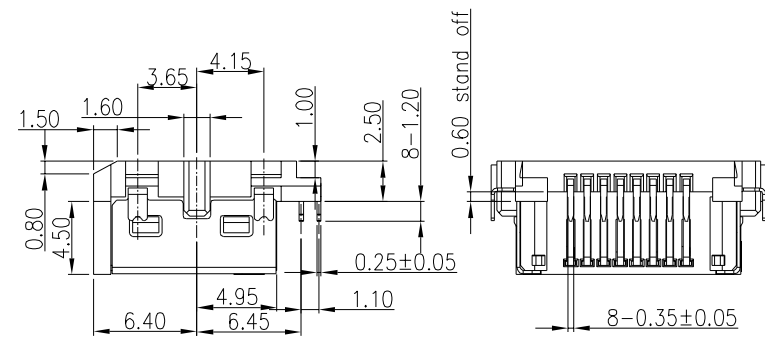
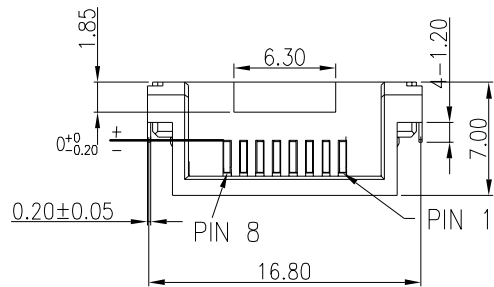

RECOMMENDED PCB LAYOUT
TOP VIEW ; TOL.±0.05
(PCB THICKNESS=1.20mm)
STAND OFF AREA

E	STOP	2	HIGH TEMP.THERMOPLASTIC	UL 94V-0 & BLACK
D	COVER	1	HIGH TEMP.THERMOPLASTIC	UL 94V-0 & BLACK
C	SHELL	1	STAINLESS STEEL	NI PLATING ALL OVER
B	8P8C CONTACT	8	PHOSPHOR BRONZE 0.25t	Au:1u" OVER ON CONTACT AREA; Matte Sn 120u" ON SOLDER TAIL; ALL OVER Ni 50u"MIN.
A	BODY	1	PA10T (No Recycling Material)	UL 94V-0 & BLACK
NO	DESCRIPTION	QTY	MATERIAL	PLATING & COLOR

UNLESS OTHERWISE SPECIFIED TOLERANCES		Singatron Enterprise Co., Ltd. 信音企業股份有限公司		
DECIMALS:	ANGLES:	TITLE	RJ45 JACK	
X :±0.5	X :±2°	DWN	PAN	PART NO. 2RJ3076-0H8211F
X.X :±0.3	X.X :±1°	CHKD	ALLEN	SCALE 4:1 UNIT: mm
X.XX :±0.2		APVD	BOYE	SIZE: A3 SHEET:1 / 2 REV: A
CUSTOMER COPY				

REV.	ECN NO OR DESCRIPTION	REVISED	DATE
A	PDR NO:T191127-2A	PAN	2020.03.12

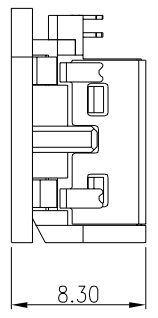
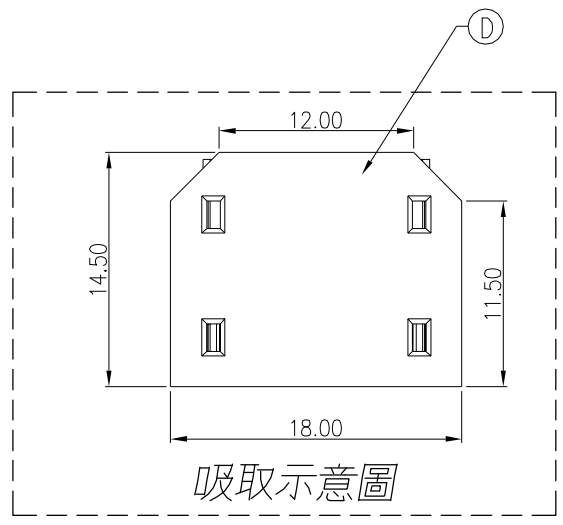
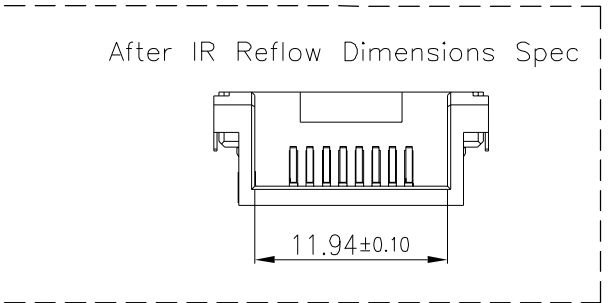
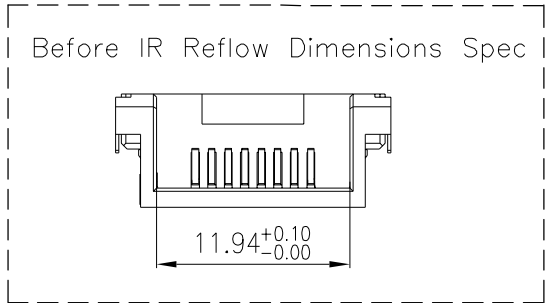
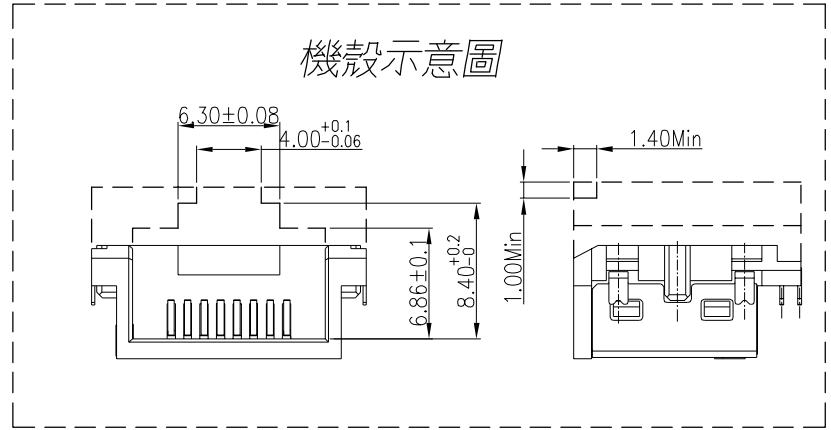
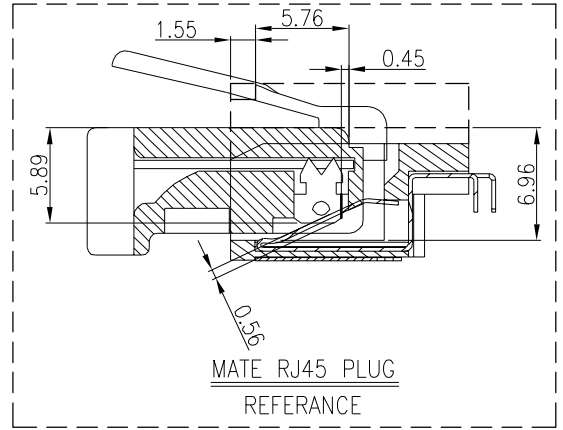

NO	DESCRIPTION	QTY	MATERIAL	PLATING & COLOR
UNLESS OTHERWISE SPECIFIED TOLERANCES			Singatron Enterprise Co., Ltd. 信音企業股份有限公司	
DECIMALS:	ANGLES:	TITLE	RJ45 JACK	
X : ±0.5	X : ±2°	DWN	PAN	PART NO. 2RJ3076-0H8211F
X.X : ±0.3	X.X : ±1°	CHKD	ALLEN	SCALE 4:1 UNIT: mm
X.XX : ±0.2		APVD	BOYE	SIZE: A3 SHEET:2/2 REV: A
CUSTOMER COPY				