

REV.	ECN NO OR DESCRIPTION	REVISED	DATE
A	PDR NO:T230316-6A	PAN	2023.09.06

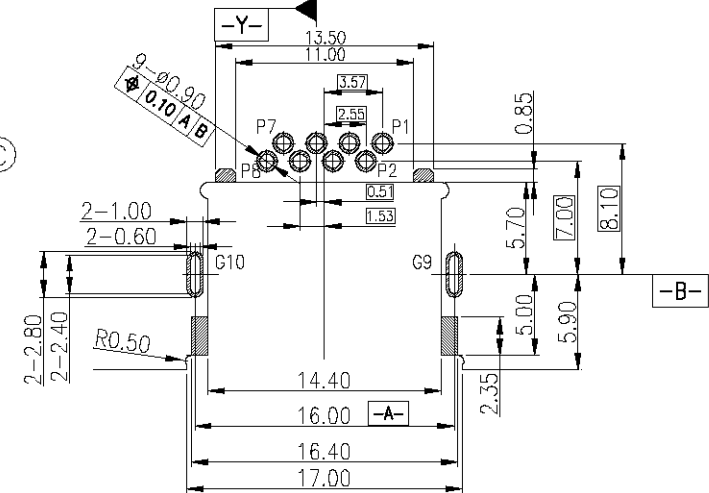
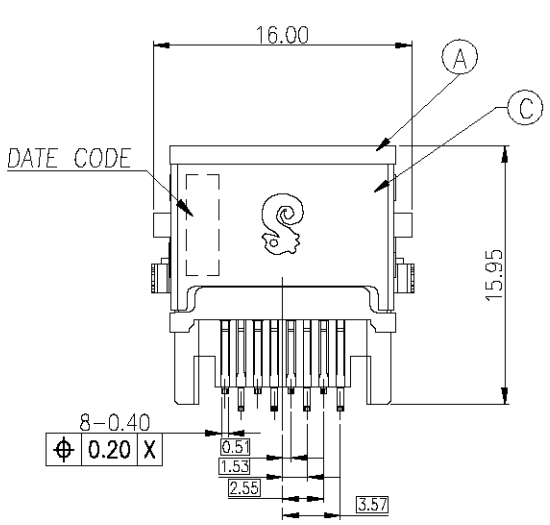
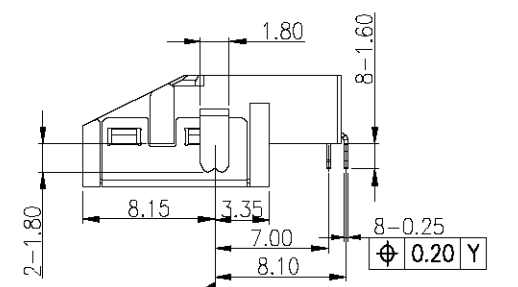
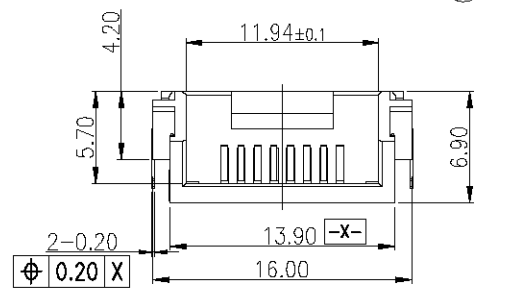
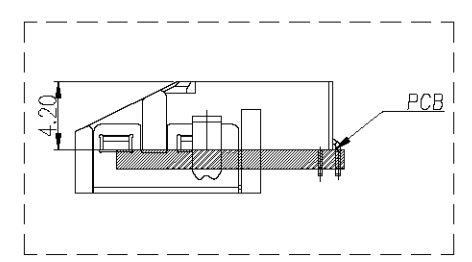
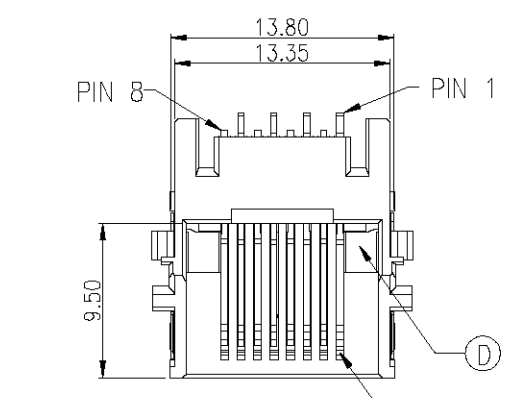

RECOMMENDED PCB LAYOUT
 TOP VIEW ; TOL.±0.05
 (PCB THICKNESS=1.20mm)
 Stand off: No trace No via

SPECIFICATIONS:

- ELECTRICAL CHARACTERISTICS:
 - CURRENT RATING: 0.5A MAX.
 - VOLTAGE RATING: 150V MAX.
 - CONTACT RESISTANCE : 50mΩ MAX.(INITIAL).
100mΩ MAX.(AFTER LIFE TEST).
 - INSULATION RESISTANCE : 100MΩ MIN.
- MECHANICAL CHARACTERISTICS:
 - DURABILITY: 5000 CYCLES.
 - INSERTION FORCE: 2.25kg MAX. WITH LATCH DEPRESSED.
 - WITHDRAWAL FORCE: 4.5kg MAX. WITH LATCH DEPRESSED.
 - OPERATING TEMPERATURE: -30℃ ~ +70℃
- MARKING: MARK "S" INSIDE OF THE CONNECTOR.
- PACKAGING : TAPE & REEL.
- TO CONFORM TO SINGATRON HAZARDOUS SUBSTANCE FREE SPEC.
- HALOGEN FREE PRODUCT IDENTIFICATION
MARK ON PRODUCT:
- HALOGEN FREE PRODUCT IDENTIFICATION LOGO
ON THE PACKAGING:
- FOR REFLOW SOLDERING LEAD-FREE PROCESS.
- PRINTED DATE CODE" YY MM DD " ON TOP OF THE CONNECTOR.

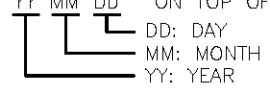

E	COVER	1	HIGH TEMP.THERMOPLASTIC	UL 94V-0 & BLACK
D	STOP	2	HIGH TEMP.THERMOPLASTIC	UL 94V-0 & YELLOW
C	SHELL	1	STAINLESS STEEL	BLACK NI PLATING ALL OVER
B	8PCS CONTACT	8	PHOSPHOR BRONZE 0.25t	Au 3u" ON CONTACT AREA; Matte Sn 120u" ON SOLDER TAIL; ALL OVER NI 50u"MIN.
A	BODY	1	HIGH TEMP.THERMOPLASTIC	UL 94V-0 & BLACK
NO	DESCRIPTION	QTY	MATERIAL	PLATING & COLOR

UNLESS OTHERWISE SPECIFIED TOLERANCES		Singatron Enterprise Co., Ltd. 	
DECIMALS:	ANGLES:	TITLE RJ45 JACK	
X ±0.5	X ±2°	DWN	PAN PART NO. 2RJ3076-0Z8211F
X.X ±0.3	X.X ±1°	CHKD	JAMES SCALE 4:1 UNIT: mm
X.XX ±0.2		APVD	BOYE SIZE: A3 SHEET: 1 / 2 REV: A
CUSTOMER COPY			

REV.	ECN NO OR DESCRIPTION	REVISED	DATE
A	PDR NO:T230316-6A	PAN	2023.09.06

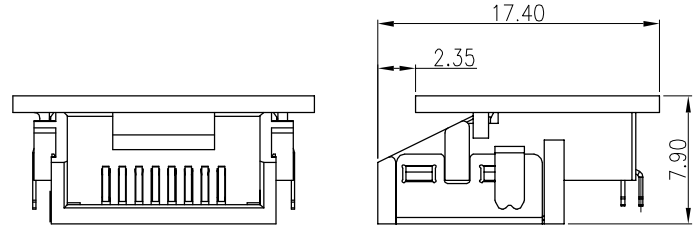
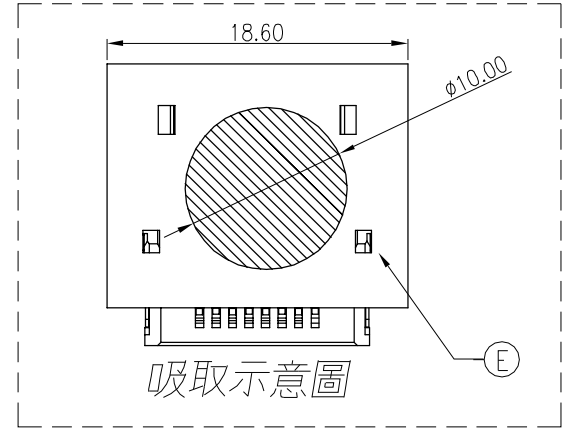
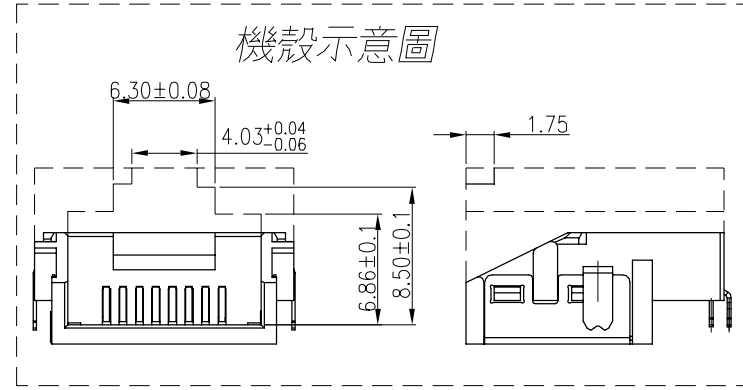
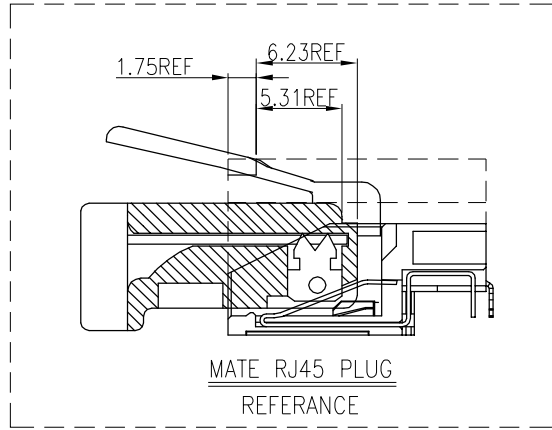

NO	DESCRIPTION	QTY	MATERIAL	PLATING & COLOR
UNLESS OTHERWISE SPECIFIED TOLERANCES			Singatron Enterprise Co., Ltd. 信音企業股份有限公司	
DECIMALS:		ANGLES:		TITLE
X	±0.5	X	±2°	RJ45 JACK
X.X	±0.3	X.X	±1°	DWN PAN PART NO. 2RJ3076-0Z8211F
X.XX	±0.2			CHKD JAMES SCALE 4:1 UNIT: mm
		APVD BOYE	SIZE: A3	SHEET: 2/2 REV: A
CUSTOMER COPY				