

REV.	ECN NO OR DESCRIPTION	REVISED	DATE
D	ECN NO.S160141-C	James	2016.03.04
E	ECN NO.S160422-C	Allen	2016.05.16
F	ECN NO.S160420-C	PENG	2016.06.01

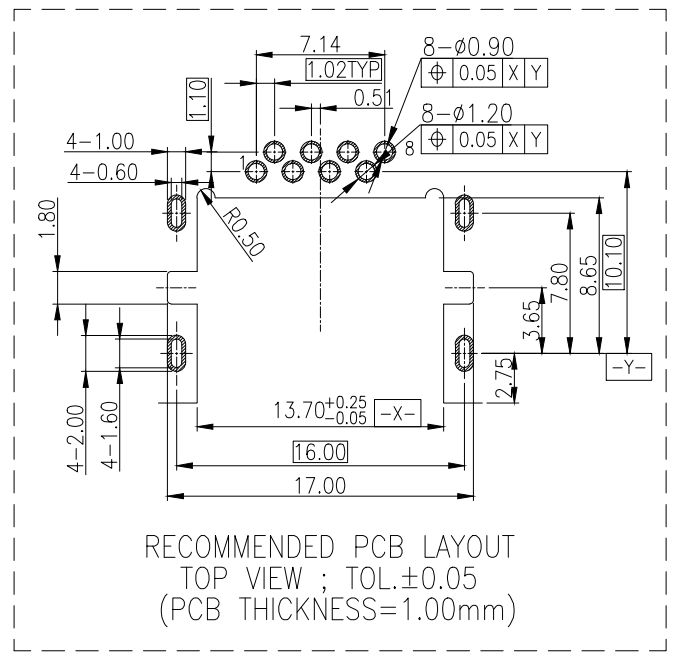

SPECIFICATIONS:

- ELECTRICAL CHARACTERISTICS:
 - CURRENT RATING: 0.5A MAX.
 - VOLTAGE RATING: 150VAC MAX.
 - CONTACT RESISTANCE: 40mΩ MAX.(INITIAL). 70mΩ MAX.(AFTER LIFE TEST).
 - INSULATION RESISTANCE: 100MΩ MIN.
- MECHANICAL CHARACTERISTICS:
 - DURABILITY: 5000 CYCLES.
 - INSERTION FORCE: 2.25Kg MAX. WITH LATCH DEPRESSED.
 - OPERATING TEMPERATURE: -30℃ ~ +85℃.
- MARKING: MARK "Ⓢ" ON TOP OF THE CONNECTOR.
- PACKAGING: TAPE & REEL.
- TO CONFORM TO SINGATRON HAZARDOUS SUBSTANCE FREE SPEC.
- HALOGEN FREE PRODUCT IDENTIFICATION
MARK ON PRODUCT: Ⓢ
ON THE PACKAGING: Ⓢ
- FOR REFLOW SOLDERING LEAD-FREE PROCESS.
- PRINTED DATE CODE "YY MM DD" ON TOP OF THE CONNECTOR.

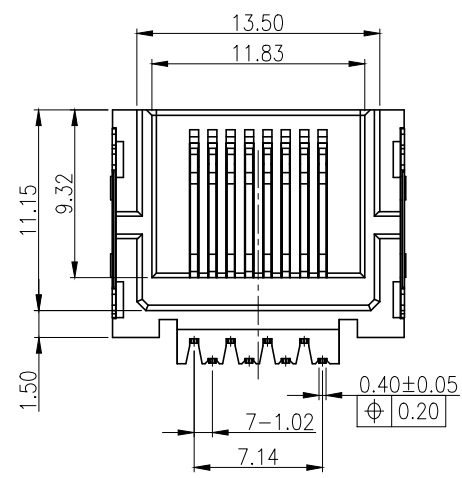
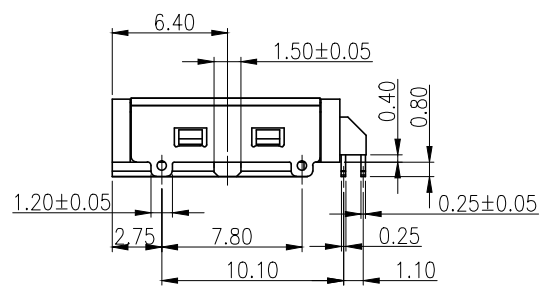
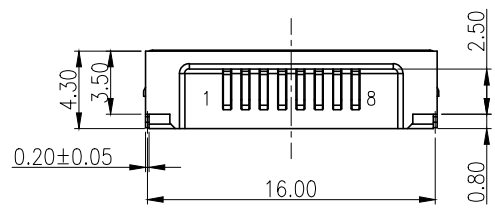
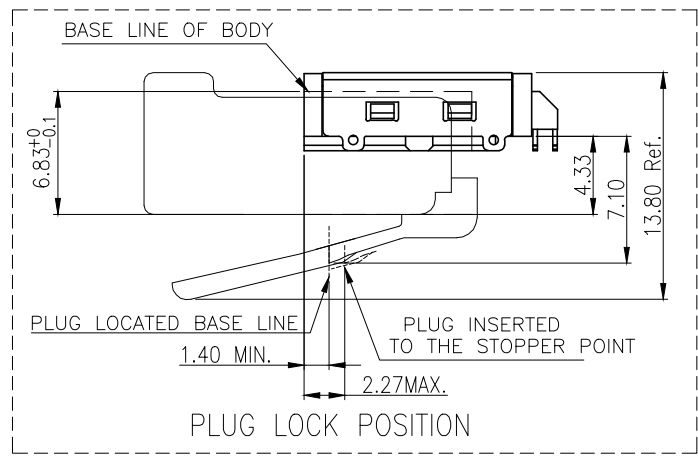
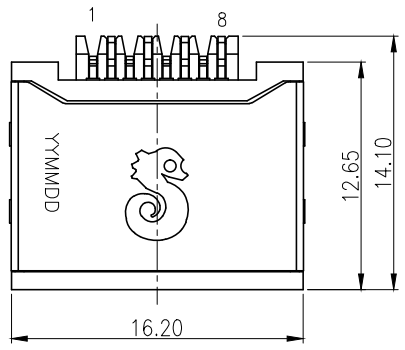
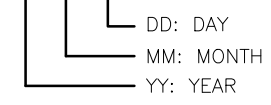

C	SHELL	1	SUS301 1/2H	Ni 50u"MIN.
B	8P8C CONTACT	8	C5210-H	GOLD 1~3u" ON CONTACT AREA; MATTE Sn 120u" ON SOLDER TAIL; ALL OVER Ni 50u"MIN.
A	BODY	1	LCP E130i UL94 V-0 (全原料)	BLACK
NO	DESCRIPTION	QTY	MATERIAL	PLATING & COLOR

UNLESS OTHERWISE SPECIFIED TOLERANCES		Singatron Enterprise Co., Ltd. 信音企業股份有限公司		
DECIMALS:	ANGLES:	TITLE	LAN JACK RJ45 DIP	
X ±0.50	X ±2°	DWN	peng	PART NO. 2RJ3079-008211F
XX ±0.30	XX ±1°	CHKD	james	SCALE 4:1 UNIT: mm
XXX ±0.20		APVD	boye	SIZE: A3 SHEET: 1 / 1 REV: F
CUSTOMER COPY				