

REV.	ECN NO OR DESCRIPTION	REVISED	DATE
A	PDR NO: T170925-1A	ALLEN	2018.05.18

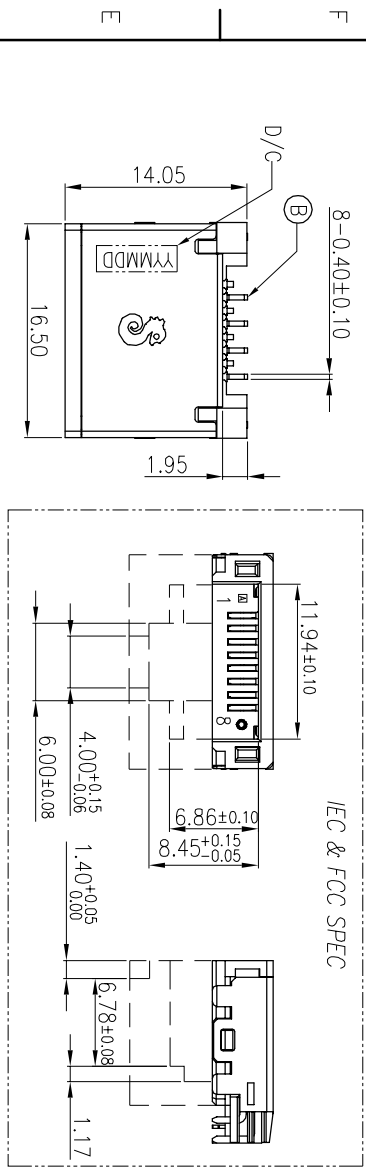

SPECIFICATIONS:

1. ELECTRICAL CHARACTERISTICS:
 - 1-1. CURRENT RATING: 1.5A MAX.
 - 1-2. VOLTAGE RATING: 150V MAX.
 - 1-3. CONTACT RESISTANCE : 50mΩ MAX.(INITIAL), 100mΩ MAX.(AFTER LIFE TEST).
 - 1-4. INSULATION RESISTANCE : 100MΩ MIN.
 - 1-5. Dielectric Withstanding Voltage : 500 V AC
2. MECHANICAL CHARACTERISTICS:
 - 2-1. DURABILITY: 5000 CYCLES.
 - 2-2. INSERTION FORCE: 2.25kg MAX. WITH LATCH DEPRESSED.
 - 2-3. WITHDRAWAL FORCE: 4.5kg MAX. WITH LATCH DEPRESSED.
 - 2-4. OPERATING TEMPERATURE: -30℃ ~ +70℃.
3. MARKING: MARK "Ⓢ" INSIDE OF THE CONNECTOR.
4. PACKAGING : TAPE & REEL.
5. TO CONFORM TO SINGATRON HAZARDOUS SUBSTANCE FREE SPEC.
6. HALOGEN FREE PRODUCT IDENTIFICATION
7. HALOGEN FREE PRODUCT IDENTIFICATION LOGO ON THE PACKAGING: Ⓢ
8. FOR REFLOW SOLDERING LEAD-FREE PROCESS.
9. PRINTED DATE CODE "YY MM DD" ON TOP OF THE CONNECTOR.

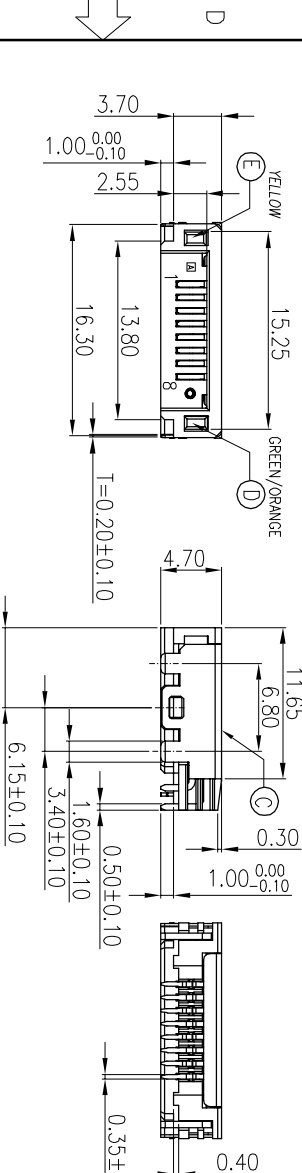

NODE	COLOR	A1-#-A2
A1(+), A2(-)	ORANGE	A1-#-A2
A3(+), A4(-)	GREEN	A3-#-A4
B1(+), B2(-)	YELLOW	B1-#-B2

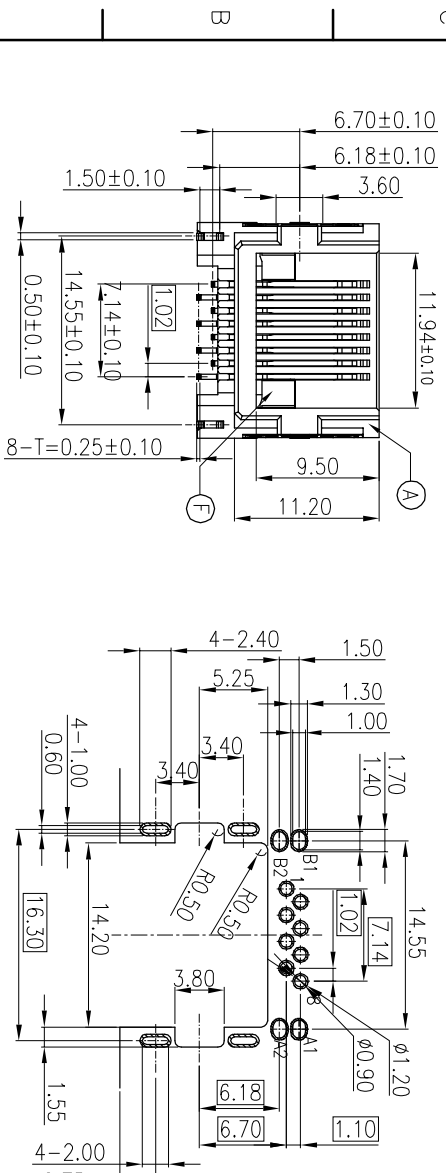
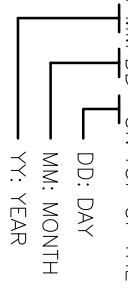

RECOMMENDED PCB LAYOUT
TOP VIEW : TOL.±0.05
(PCB THICKNESS=1.00mm)

F	STOP	2	HIGH TEMP.THERMOPLASTIC	UL 94V-0 & Yellow
E	LED 2	1	YELLOW	White Sn 80μ" ON SOLDER TAIL.
D	LED 1	1	GREEN/ORANGE	White Sn 80μ" ON SOLDER TAIL.
C	SHELL	1	STAINLESS STEEL	NICKEL
B	TERMINAL	8	PHOSPHOR BRONZE	NI PLATING ALL OVER G/F ON CONTACT AREA, White Sn 80μ" ON SOLDER TAIL; ALL OVER NI 50μ"MIN.
A	HOUSING	1	HIGH TEMP.THERMOPLASTIC	UL 94V-0 & BLACK
NO	DESCRIPTION	QTY	MATERIAL	PLATING & COLOR

Singatron Enterprise Co., Ltd.
信晉企業股份有限公司

TITLE	R445 JACK	
DRAWN	ALLEN	PART NO. 2RJ3081-128211F
CHECKED	JAMES	SCALE 4:1 UNIT: mm
APPROVED	BOYE	SIZE: A3 SHEET1 OF 2 REV. A
CUSTOMER COPY		

1 2 3 4 5 6 7 8
A B C D E F
A B C D E F
A B C D E F

REV.	ECN NO OR DESCRIPTION	REVISED	DATE
A	PDR NO: T170925-1A	ALLEN	2018.05.18

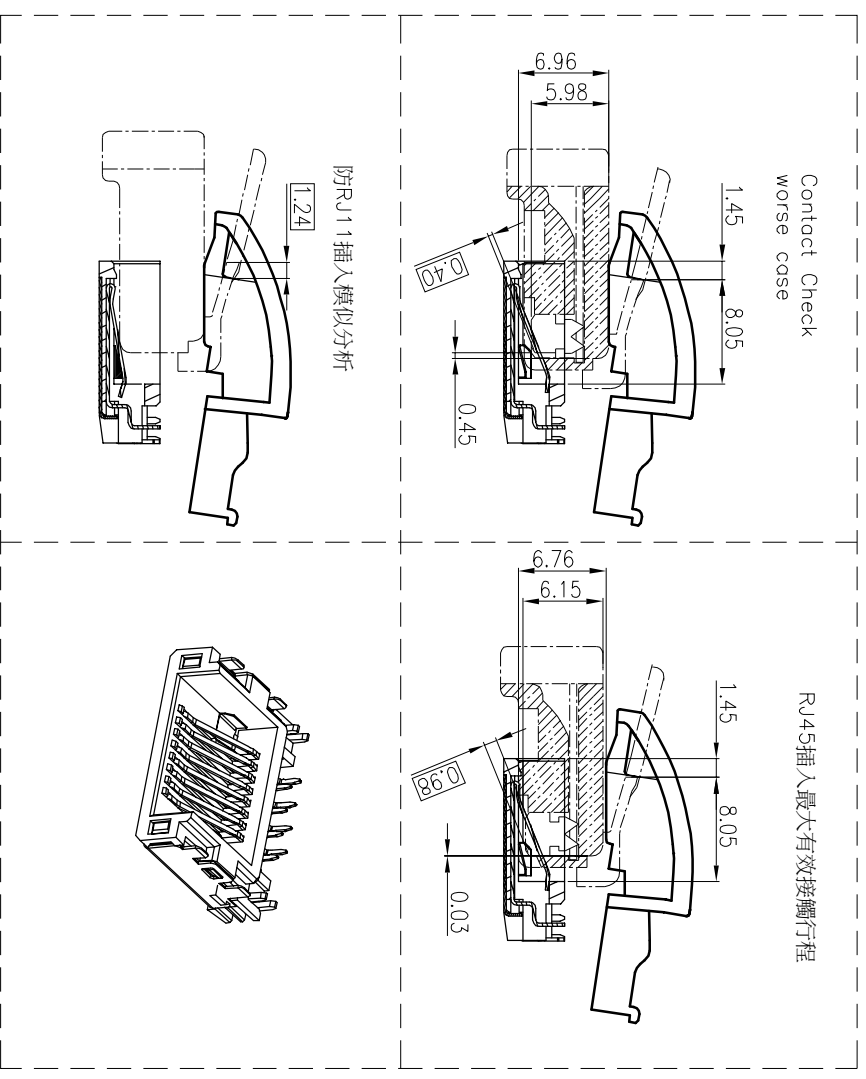

NO	DESCRIPTION	QTY	MATERIAL	PLATING & COLOR
UNLESS OTHERWISE SPECIFIED TOLERANCES				
DECIMALS: ANGLES:				
X	:±0.5	X	:±2°	
X.X	:±0.3	X.X	:±1°	
X.XX	:±0.2			
TITLE: RJ45 JACK				
DWN	ALLEN	PART NO.	2RJ3081-128211F	
CHKD	JAMES	SCALE	4:1	UNIT: mm
APVD	BOYE	SIZE: A3	SHEET2 OF 2	REV: A
CUSTOMER COPY				

 Singatron Enterprise Co., Ltd.
信晉企業股份有限公司