

REV.	ECN NO OR DESCRIPTION	REVISED	DATE
A	PDR NO: T180621-1A	ALLEN	2019.04.10

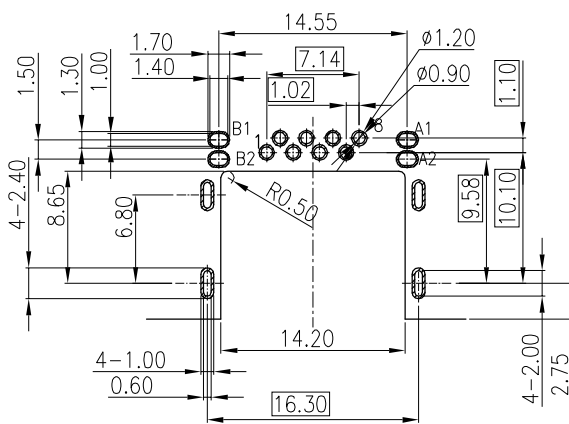
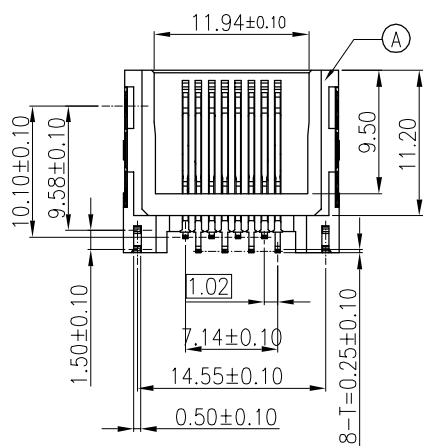
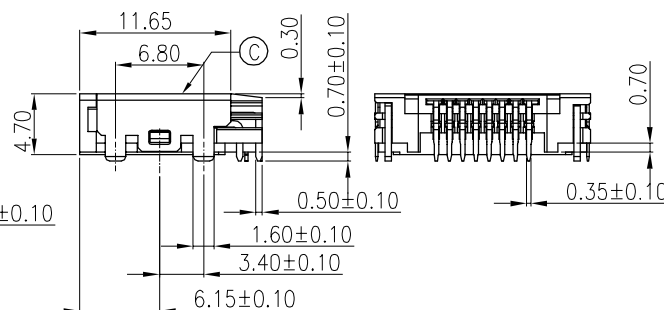
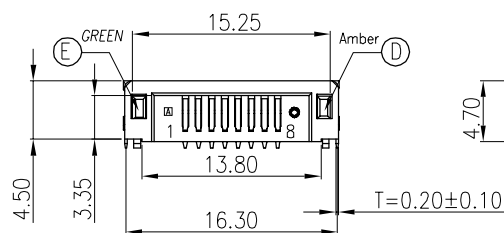
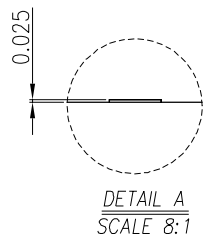
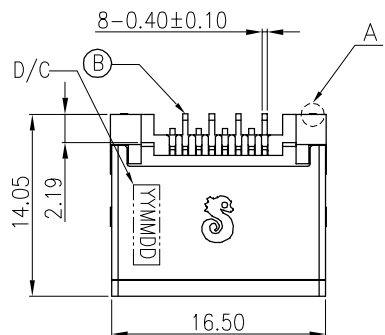

RECOMMENDED PCB LAYOUT
TOP VIEW ; TOL.±0.05
(PCB THICKNESS=1.00mm)

SPECIFICATIONS:

- ELECTRICAL CHARACTERISTICS:
 - CURRENT RATING: 1.5A MAX.
 - VOLTAGE RATING: 150V MAX.
 - CONTACT RESISTANCE : 50mΩ MAX.(INITIAL).
100mΩ MAX.(AFTER LIFE TEST).
 - INSULATION RESISTANCE : 100MΩ MIN.
 - Dielectric Withstanding Voltage :1500 V AC & 2250 V DC
- MECHANICAL CHARACTERISTICS:
 - DURABILITY: 5000 CYCLES.
 - INSERTION FORCE: 2.25Kg MAX. WITH LATCH DEPRESSED.
 - WITHDRAWAL FORCE: 4.5Kg MAX. WITH LATCH DEPRESSED.
 - OPERATING TEMPERATURE: -30℃ ~ +70℃.
- MARKING: MARK "S" INSIDE OF THE CONNECTOR.
- PACKAGING : TAPE & REEL.
- TO CONFORM TO SINGATRON HAZARDOUS SUBSTANCE FREE SPEC.
- HALOGEN FREE PRODUCT IDENTIFICATION
MARK ON PRODUCT:
- HALOGEN FREE PRODUCT IDENTIFICATION LOGO
ON THE PACKAGING:
- FOR REFLOW SOLDERING LEAD-FREE PROCESS.
- PRINTED DATE CODE "YY MM DD " ON TOP OF THE CONNECTOR.

DD: DAY
MM: MONTH
YY: YEAR

E	LED 2	1		GREEN
D	LED 1	1		Amber
C	SHELL	1	STAINLESS STEEL	NICKEL
B	TERMINAL	8	PHOSPHOR BRONZE	G/F ON CONTACT AREA; Matte Sn 80u" ON SOLDER TAIL; ALL OVER Ni 50u" MIN.
A	HOUSING	1	HIGH TEMP.THERMOPLASTIC	UL 94V-0 & BLACK
NO	DESCRIPTION	QTY	MATERIAL	PLATING & COLOR
UNLESS OTHERWISE SPECIFED TOLERANCES			Singatron Enterprise Co., Ltd. 	
DECIMALS:	ANGLES:	TITLE	RJ45 JACK	
X :±0.5	X :±2°	DWN	ALLEN	PART NO. 2RJ3081-1E8211F
X.X :±0.3	X.X :±1°	CHKD	JAMES	SCALE 4:1 UNIT: mm
X.XX :±0.2		APVD	BOYE	SIZE: A3 SHEET:1 OF 2 REV: A
CUSTOMER COPY				

REV.	ECN NO OR DESCRIPTION	REVISED	DATE
A	PDR NO: T180621-1A	ALLEN	2019.04.10

5.70 Plug Worst case 分析

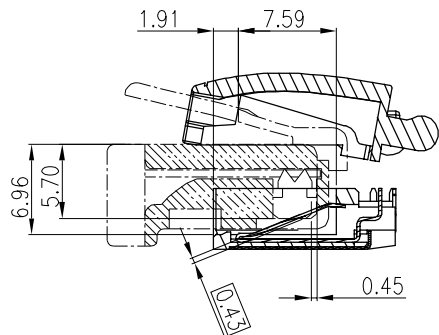

5.89 Plug Worst case 分析

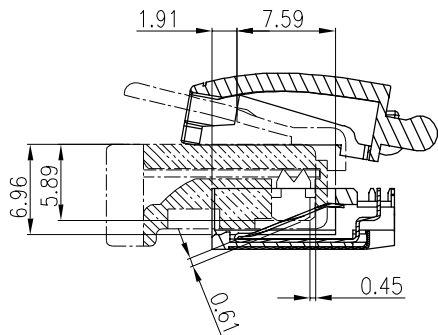

6.40 Plug Worst case 分析

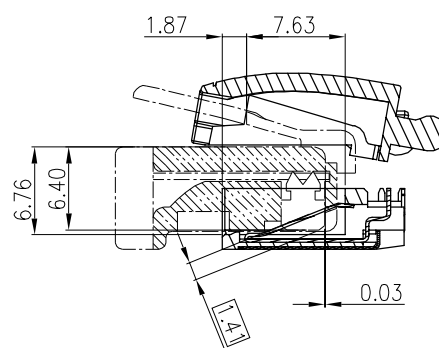

防RJ11插入模拟分析

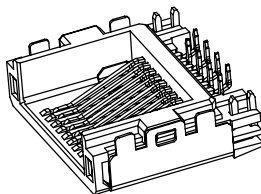
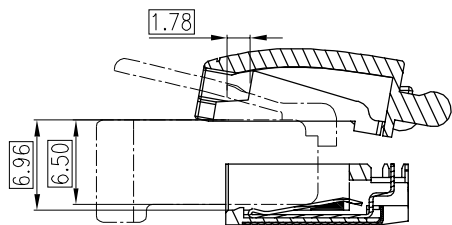

IEC & FCC SPEC

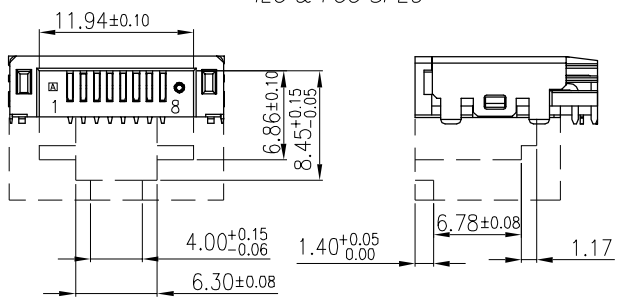

NODE	COLOR		Wavelength	DC Forward Current	Forward Voltage
A1(+) A2(-)	Amber	A1↔A2	λd 584~597	6mA	3.3V
B1(+) B2(-)	GREEN	B1↔B2	λd 564~576	6mA	3.3V

NO	DESCRIPTION	QTY	MATERIAL	PLATING & COLOR
UNLESS OTHERWISE SPECIFIED TOLERANCES		Singatron Enterprise Co., Ltd. 信音企業股份有限公司		
DECIMALS: ANGLES:		TITLE RJ45 JACK		
X : ±0.5	X : ±2°	DWN	ALLEN	PART NO. 2RJ3081-1E8211F
X.X : ±0.3	X.X : ±1°	CHKD	JAMES	SCALE 4:1 UNIT: mm
X.XX : ±0.2		APVD	BOYE	SIZE: A3 SHEET2 OF 2 REV: A
CUSTOMER COPY				