

REV	ECN NO OR DESCRIPTION	REVISED	DATE
A	PDR NO.S120307-12A	WINNIE	2013.11.21

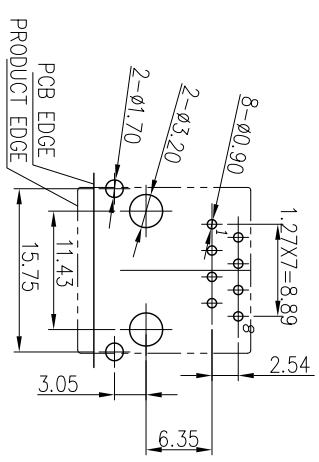
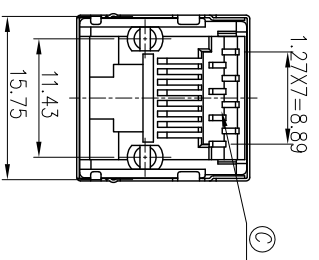
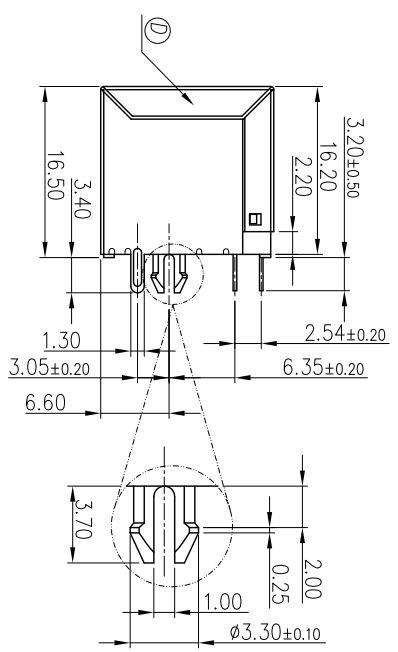
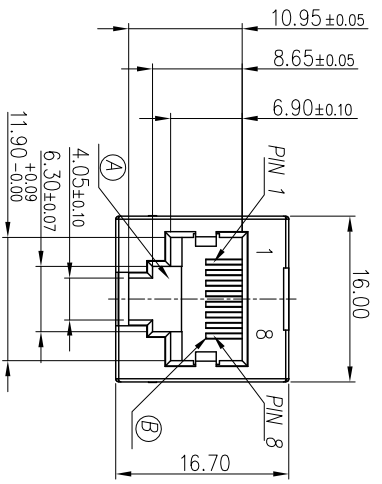

NOTES:

1. ELECTRICAL:

- 1. VOLTAGE RATING : 125 VAC.
- 2. CURRENT RATING : 1.5 AMP.
- 3. CONTACT RESISTANCE : 45 MILLIOHMS MAX.
- 4. INSULATION RESISTANCE : 1000 MEGOHMS MIN. AT 500 VDC.
- 5. DIELECTRIC STRENGTH : 1000 VAC 60HZ, 1MIN.
: PIN TO PIN 1000 VAC RMS 60HZ, 1MIN.
: PIN TO SHIELD 1500 VAC RMS 60HZ, 1MIN.

2. MECHANICAL:

- 1. OPERATING LIFE : 750 CYCLES MIN.
- 2. PCB RETENTION FORCE PRE-SOLDER : 0.454KGF MIN.
- 3. PCB RETENTION FORCE POST-SOLDER : 4.54KGF MIN.

3. ENVIRONMENTAL:

- 1. STORAGE : -40°C TO +85°C.
- 2. OPERATION : -40°C TO +85°C.

MATES WITH MODULAR PLUG CONFORMING TO FCC PART 68, SUBPART F.
4. PART NUMBER : 2RJ3101-008512H

- PACKAGING: 08--8 PIN
- HOUSING& INSERT COLOR: 2--TRAY PACKAGING
- 1--POLYESTER BK. 5--Gold 3u" Plating
- CONTACT PLATING: PIN QUANTITY

- 5. TO CONFORM TO SINGATRON HAZARDOUS SUBSTANCE FREE SPECIFICATION
- 6. GREEN PRODUCT IDENTIFICATION LABEL ON PACKAGING: **G.P. PASS**

D	SHEILD	1	BRASS T=0.20	PLATED NICKEL BY 50U"±50U"
C	INSERT	1	HIGH TEMP.THERMOPLASTIC	UL94V-0 & BLACK
B	CONTACT	8	PHOSPHOR BRONZE, T=0.35	GOLD 3u" PLATING ON CONTACT AREA WATT SN PLATING ON SOLDER TAIL ALL OVER NICKEL PLATED.
A	HOUSING	1	HIGH TEMP.THERMOPLASTIC	UL94V-0 & BLACK
NO	DESCRIPTION	QTY	MATERIAL	PLATING & COLOR
UNLESS OTHERWISE SPECIFIED TOLERANCES				
Singatron Enterprise Co., Ltd. 信普企業股份有限公司				
DECIMALS: ANGLES:				
X	:±0.5	X	:±2°	
X.X	:±0.3	X.X	:±1°	
X.XX	:±0.2			
TITLE R45 TOP ENTRY W/SHIELD				
DMN	WINNIE	PART NO.2RJ3101-008512H		
CHKD	SOLDER	SCALE 2:1	UNIT: mm	
APVD	BOYE	SIZE: A3	SHEET: 1 OF 1	REV: A
CUSTOMER COPY				