

REV.	ECN NO OR DESCRIPTION	REVISED	DATE
A	PDR NO:T230615-4A	PAN	2024.01.12

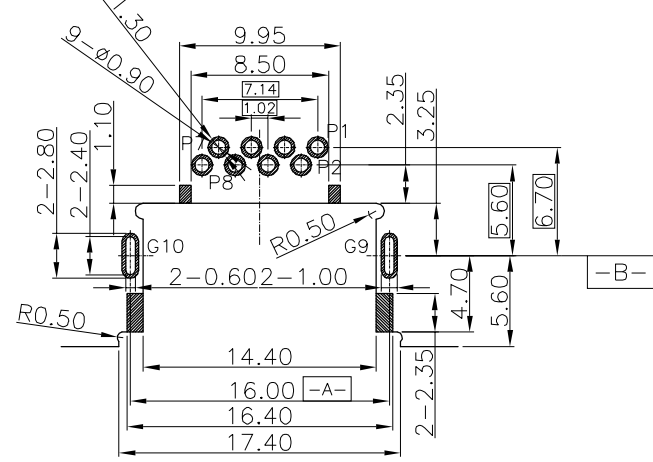
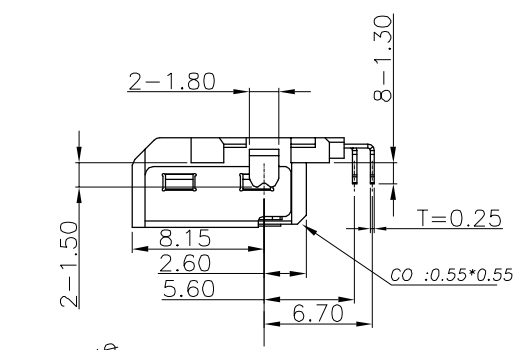
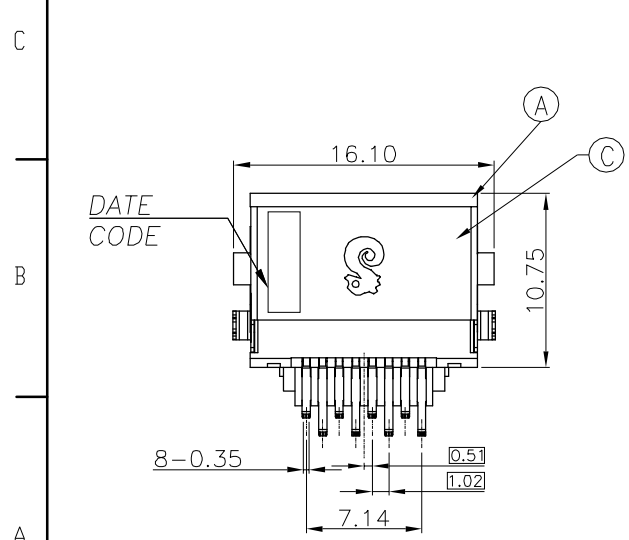
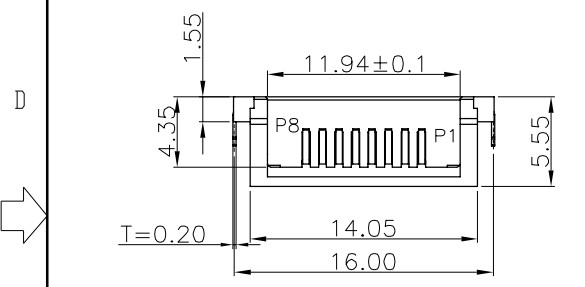
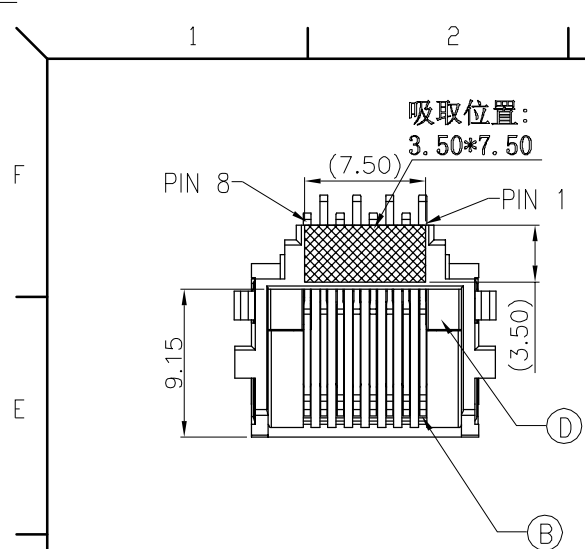

RECOMMENDED PCB LAYOUT
TOP VIEW ; TOL.±0.05
(PCB THICKNESS=1.00mm)
Stand off: No trace No via

SPECIFICATIONS:

- ELECTRICAL CHARACTERISTICS:
 - CURRENT RATING: 0.5A MAX.
 - VOLTAGE RATING: 150V MAX.
 - CONTACT RESISTANCE : 50mΩ MAX.(INITIAL).
100mΩ MAX.(AFTER LIFE TEST).
 - INSULATION RESISTANCE : 100MΩ MIN. 50MΩ MIN. after test . 500V DC
 - Dielectric Withstanding Voltage : 500V AC Max.
- MECHANICAL CHARACTERISTICS:
 - DURABILITY: 5000 CYCLES.
 - INSERTION FORCE: 2.25Kg MAX. WITH LATCH DEPRESSED.
 - WITHDRAWAL FORCE: 4.5Kg MAX. WITH LATCH DEPRESSED.
 - OPERATING TEMPERATURE: -30℃ ~ +75℃.
- MARKING: MARK "S" INSIDE OF THE CONNECTOR.
- PACKAGING : TAPE & REEL.
- TO CONFORM TO SINGATRON HAZARDOUS SUBSTANCE FREE SPEC.
- HALOGEN FREE PRODUCT IDENTIFICATION
MARK ON PRODUCT:
- HALOGEN FREE PRODUCT IDENTIFICATION LOGO
ON THE PACKAGING:
- FOR REFLOW SOLDERING LEAD-FREE PROCESS.
- PRINTED DATE CODE" YY MM DD " ON TOP OF THE CONNECTOR.
 - DD: DAY
 - MM: MONTH
 - YY: YEAR

D	STOP	2	HIGH TEMP.THERMOPLASTIC	UL 94V-0 & YELLOW
C	SHELL	1	STAINLESS STEEL 0.2T	NI PLATING ALL OVER
B	8PCS CONTACT	8	PHOSPHOR BRONZE 0.25T	G/F ON CONTACT AREA; Matte Sn 120u" ON SOLDER TAIL; ALL OVER Ni 50u"MIN.
A	BODY	1	HIGH TEMP.THERMOPLASTIC	UL 94V-0 & BLACK
NO	DESCRIPTION	QTY	MATERIAL	PLATING & COLOR

UNLESS OTHERWISE SPECIFIED TOLERANCES		Singatron Enterprise Co., Ltd. 		
DECIMALS:		TITLE		
X	±0.5	X	±2°	RJ45 JACK
X.X	±0.3	X.X	±1°	DWN PAN PART NO.2RJ3121-008211F
X.XX	±0.2	APVD	BOYE	SCALE 4:1 UNIT: mm
		APVD	BOYE	SHEET:1 / 2 REV: A
CUSTOMER COPY				

1 2 3 4 5 6 7 8

REV.	ECN NO OR DESCRIPTION	REVISED	DATE
A	PDR NO:T230615-4A	PAN	2024.01.12

F

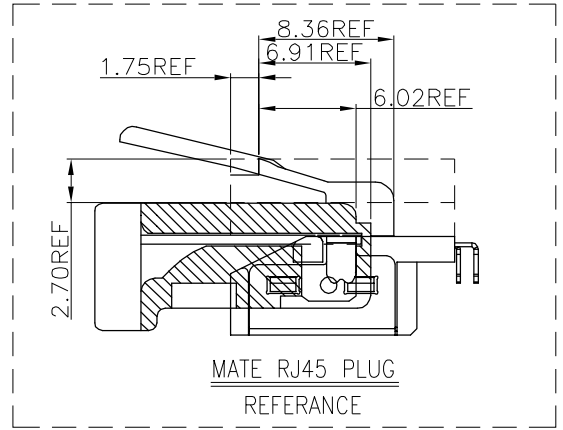

機殼示意圖

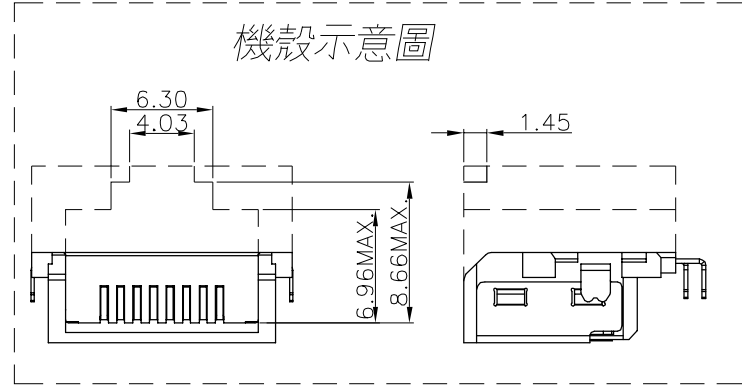

E

E

D

D

C

C

B

B

A

A

NO	DESCRIPTION	QTY	MATERIAL	PLATING & COLOR
UNLESS OTHERWISE SPECIFIED TOLERANCES			Singatron Enterprise Co., Ltd. 信音企業股份有限公司	
DECIMALS:		ANGLES:	TITLE	RJ45 JACK
X	:±0.5	X	:±2°	DWN PAN PART NO. 2RJ3121-008211F
X.X	:±0.3	X.X	:±1°	CHKD Allen SCALE 4:1 UNIT: mm
X.XX	:±0.2			APVD BOYE SIZE: A3 SHEET:2/2 REV: A
CUSTOMER COPY				

1 2 3 4 5 6 7 8