

REV.	ECN NO OR DESCRIPTION	REVISED	DATE
A	PRODUCT RELEASED	CHARLIE	2009.4.10

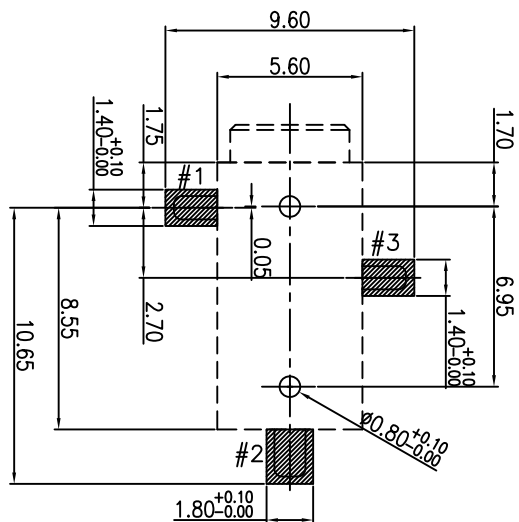

PCB LAYOUT TOLERANCE ±0.05
PRINTED SIDE

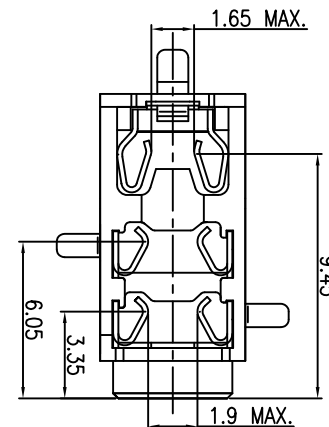
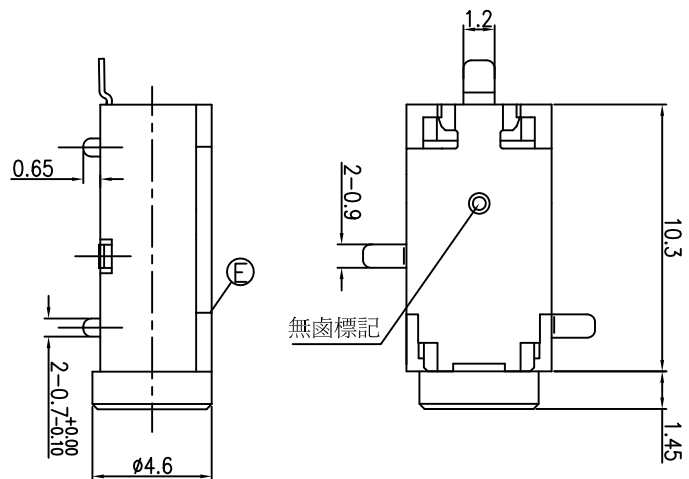
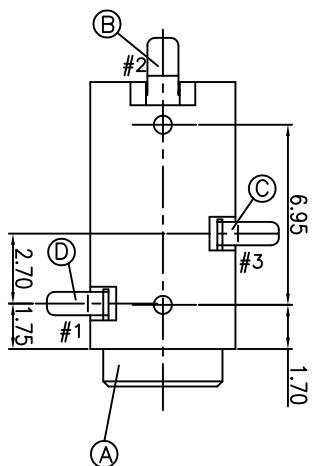
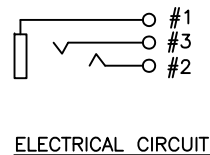
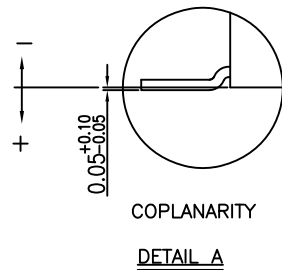
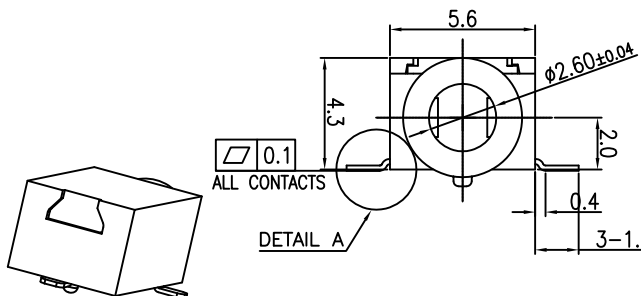

SPECIFICATIONS:

- SEE 2SJ-0259 SERIES PHONE JACKS SPECIFICATION.
- PACKING: TAPE & REEL
- TO CONFORM TO THE SINGATRON HAZARDOUS SUBSTANCE FREE SPEC.
- HALOGEN FREE PRODUCT IDENTIFICATION MARK ON PRODUCT:
- HALOGEN PRODUCT IDENTIFICATION LABEL ON PACKAGING:
- FOR REFLOW SOLDERING LEAD-FREE PROCESS.
- SOLDER HEAT RESISTANCE REFLOW SOLDERING 260°C 10SECS.
- DATE CODE: YY MM DD

Day
Month
Year

E	COVER	1	HIGH TEMP. THERMOPLASTIC UL 94V-0	BLACK COLOR
D	EARTH TERMINAL	1	COPPER ALLOY 0.2t	GOLD FLASH
C	RING TERMINAL	1	COPPER ALLOY 0.2t	GOLD FLASH
B	TIP SPRING	1	COPPER ALLOY 0.2t	GOLD FLASH
A	BODY	1	HIGH TEMP. THERMOPLASTIC UL 94V-0	BLACK COLOR
NO	DESCRIPTION	QTY	MATERIAL	PLATING & COLOR
UNLESS OTHERWISE SPECIFIED TOLERANCES			Singatron Enterprise Co., Ltd. 信音企業股份有限公司	
DECIMALS:		ANGLES:	TITLE	
X	:±0.5	X	:±2'	DWN CHARLIE
X.X	:±0.3	X.X	:±1'	CHKD RYAN
X.XX	:±0.2			APVD ROBIN
			2.5Ø PHONE JACK	
			PART NO. 2SJ-0259-007	
			SCALE 5:1	UNIT: mm
			SIZE: A3	SHEET: 10F1
			REV: A	
CUSTOMER COPY				