

REV.	ECN NO OR DESCRIPTION	REVISED	DATE
C	ECN NO.920008	BERYL	2005.6.24
D	ADD DATE CODE	HAIHUA	7/30'07
E	依ECR要求配合實物修正圖面 ECN NO.C100068	kim	2010.04.07

SPECIFICATION:

- CONTACT RESISTANCE: 20 mΩ MAX.
- INSULATION RESISTANCE: 100 MΩ MIN. AT 250V DC.
- DIELECTRIC STRENGTH: 250V AC 1 MINUTE.
- LIFE TEST:
JACK SHALL WITHSTAND 5000 CYCLES OF INSERTION AND WITHDRAWAL WITH TESTING PLUG, AFTER TEST THE CONTACT RESISTANCE SHALL NOT EXCEED 0.1Ω
- MEASURING CONDITION:
TEMPERATURE: FROM 5°C TO 35°C
RELATIVE HUMIDITY: FROM 40% TO 85%
- INSERTION FORCE: 0.4Kg~1.6Kg.
- WITHDRAWAL FORCE: 0.4Kg~1.2Kg.
- SOLDER HEAT RESISTANCE: WAVE SOLDERING 260°C 10SECS.
- TO CONFORM TO THE "SE-01-001" & "ROHS DIRECTIVE"
- GREEN PRODUCT IDENTIFICATION MARK IN JACK:
- GREEN PRODUCT IDENTIFICATION LABEL IN PACKING: **G.P. PASS**
- FOR WAVE SOLDERING LEAD-FREE PRODUCT.
- PRINTED DATE CODE "YYMMDD" ON TOP OF CONNECTOR.

YY MM DD
 DD: DAY
 MM: MONTH
 YY: YEAR

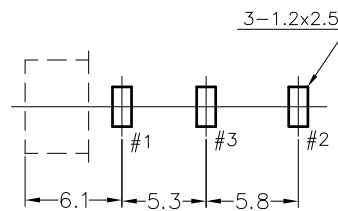
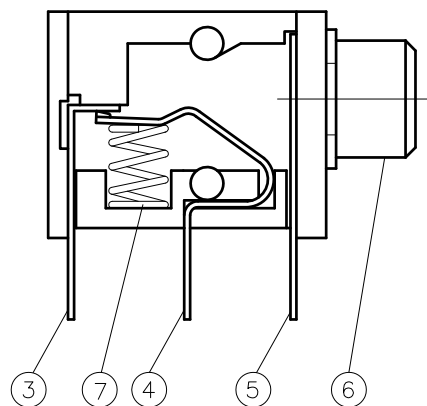
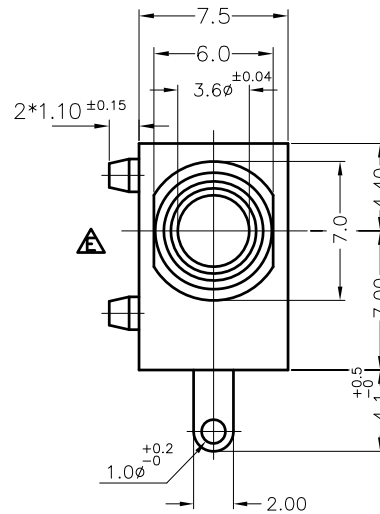
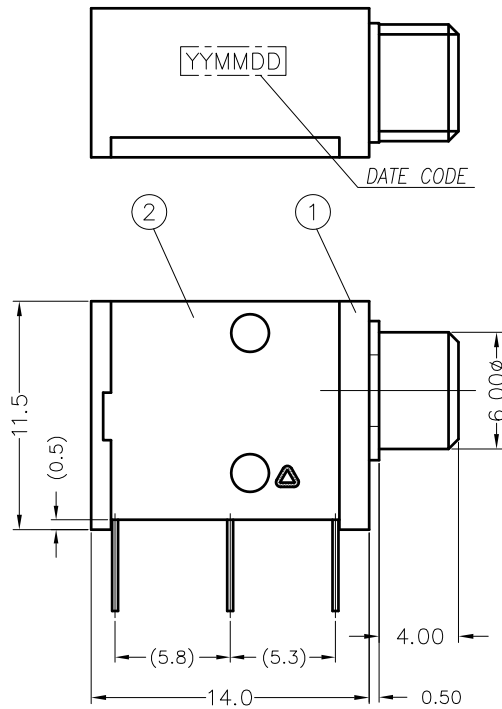

PCB LAYOUT (TOP VIEW)
 TOLERANCE: ±0.05

CIRCUIT:

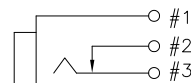

7	COIL SPRING	1	SWRS	
6	METAL	1	BRASS	NICKEL PLATING
5	TERMINAL	1	BRASS 0.3t	SILVER PLATING
4	TIP SPRING	1	BRASS 0.3t	SILVER PLATING
3	SHUNT TERMINAL	1	BRASS 0.3t	SILVER PLATING
2	COVER	1	POLYCARBONATE UL 94V-2	TRANSPARENT COLOR
1	BODY	1	PBT UL 94V-0	BLACK COLOR
NO	DESCRIPTION	QTY	MATERIAL	PLATING&COLOR
UNLESS OTHERWISE SPECIFIED TOLERANCES			Singatron Electronic(Chung-Shan) Co., Ltd. 信音電子(中山)有限公司	
DECIMALS:		ANGLES:		TITEL
X	:±0.5	X	:±2°	3.5φ EARPONE JACK
X.X	:±0.3	X.X	:±1°	DWN kim 2010.04.07 PART NO. 2SJ-03603N23
X.XX	:±0.2			CHKD ROBIN SCALE: N/A UNIT: mm
				APVD SEAN SIZE: A4 SHEET: 10F1 REV: E
CUSTOMER COPY				