

REV. A	ECN NO. PRODUCT RELEASE	OR DESCRIPTION	DESCRIPTION	REVISED	DATE
				WZJ_WEI	2015.07.07

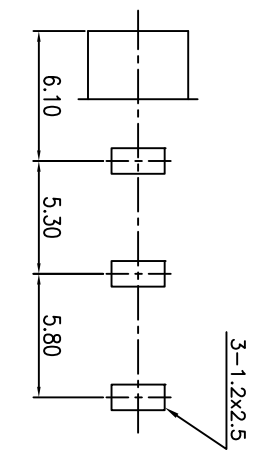

PCB LAYOUT TOL. ±0.05

- SPECIFICATION:
- CONTACT RESISTANCE: 30 mΩ MAX.
 - INSULATION RESISTANCE: 100 MΩ MIN. AT 250V DC.
 - DIELECTRIC STRENGTH: 250V AC 1 MINUTE.
 - LIFE TEST:
JACK SHALL WITHSTAND 5000 CYCLES OF INSERTION AND WITHDRAWAL WITH TESTING PLUG, AFTER TEST THE CONTACT RESISTANCE SHALL NOT EXCEED 0.1Ω
 - MEASURING CONDITION: TEMPERATURE: FROM 5°C TO 35°C
RELATIVE HUMIDITY: FROM 40% TO 85%
 - ELECTRICAL CIRCUIT.

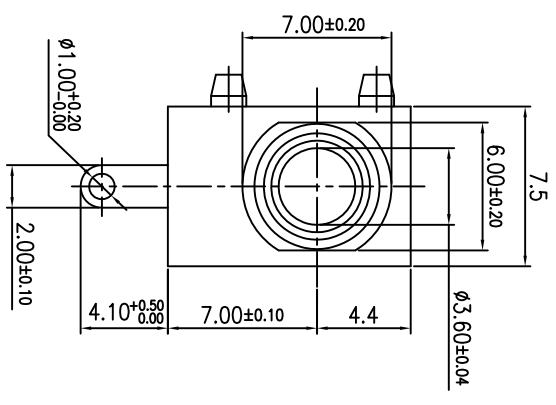
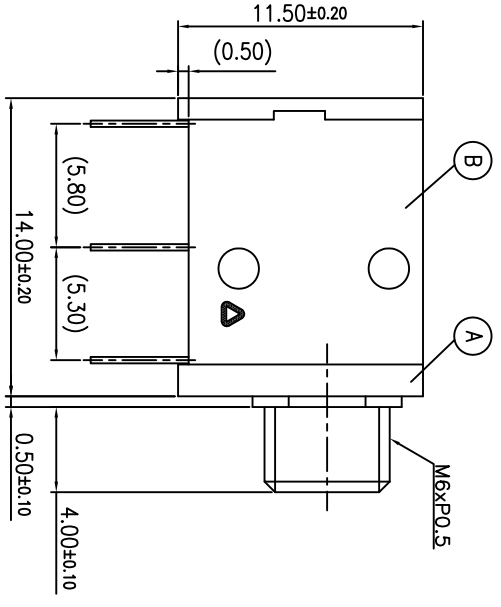
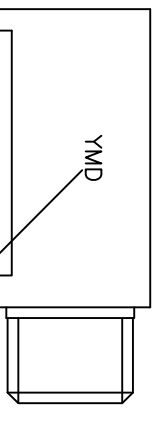
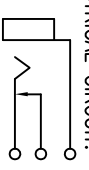

- INSERTION FORCE: 0.4kgf ~ 1.6kgf.
- WITHDRAWAL FORCE: 0.4kgf ~ 1.2kgf.
- TO CONFORM TO THE "SE-01-001" & "ROHS DIRECTIVE"
- GREEN PRODUCT IDENTIFICATION MARK IN JACK:
- GREEN PRODUCT IDENTIFICATION LABEL IN PACKING: **G.P. PASS**
- FOR LEAD-FREE PRODUCT.
- SOLDER HEAT RESISTANCE: WAVE SOLDERING 260°C 10SECS.
- PRINTED DATE CODE "YMD ON TOP OF CONNECTOR."

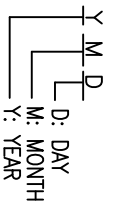

G	COIL SPRING	1	SWRS	N/A
F	METAL	1	BRASS	G/F PLATING
E	TERMINAL	1	BRASS 0.3t	SILVER PLATING
D	TIP SPRING	1	BRASS 0.3t	SILVER PLATING
C	SHUNT TERMINAL	1	BRASS 0.3t	SILVER PLATING
B	COVER	1	POLYCARBONATE UL94V-2	TRANSPARENT
A	BODY	1	PBT UL 94V-0	BLACK COLOR
NO	DESCRIPTION	QTY	MATERIAL	PLATING & COLOR

UNLESS OTHERWISE SPECIFIED TOLERANCES

TITLE: Singatron Enterprise Co., Ltd.
信音企業股份有限公司

DECIMALS: ANGLES: TITLE: Ø3.5 PHONE JACK

X : ±0.5 X : ±2°
X.X : ±0.3 X.X : ±1°
X.XX : ±0.2

DWN	ZhuJun-Wei	PART NO.	2SJ-03603T34H
CHKD	ZF-Zhou	SCALE	4:1
APVD	15/7/14	UNIT:	mm
	15/7/14	SIZE:	A3
		SHEET:	10F1
		REV:	A

CUSTOMER COPY