

REV.	ECN NO OR DESCRIPTION	REVISED	DATE
C	ECN NO: 920008	EVEN	2005.7.8
D	ECN NO: C100378	LONGJIANG	2010.11.10
E	ECN NO: C150148 Modify material	REX	2015.12.03

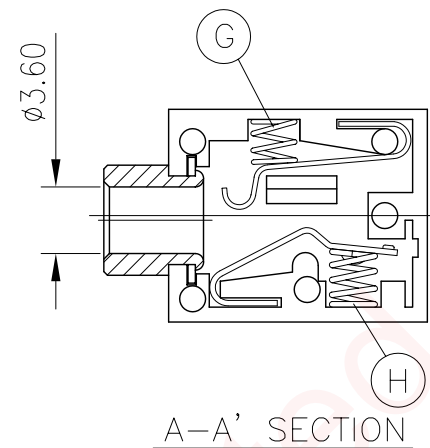

SPECIFICATION:

- CONTACT RESISTANCE: 30 mΩ MAX.
- INSULATION RESISTANCE: 100 MΩ MIN. AT 250V DC.
- DIELECTRIC STRENGTH: 250V AC 1 MINUTE.
- LIFE TEST:
JACK SHALL WITHSTAND 5000 CYCLES OF INSERTION AND WITHDRAWAL WITH TESTING PLUG, AFTER TEST THE CONTACT RESISTANCE SHALL NOT EXCEED 0.1Ω
- MEASURING CONDITION:
TEMPERATURE: FROM 5°C TO 35°C
RELATIVE HUMIDITY: FROM 40% TO 85%
- INSERTION FORCE: 0.4Kg~1.6Kg.
- WITHDRAWAL FORCE: 0.4Kg~1.4Kg.
- SOLDER HEAT RESISTANCE: WAVE SOLDERING 260°C 10 SECS.
- TO CONFORM TO THE "SE-01-001" & "ROHS DIRECTIVE"
- GREEN PRODUCT IDENTIFICATION MARK IN JACK:
- GREEN PRODUCT IDENTIFICATION LABEL IN PACKING: **G.P. PASS**
- FOR WAVE SOLDERING LEAD-FREE PROCESS.

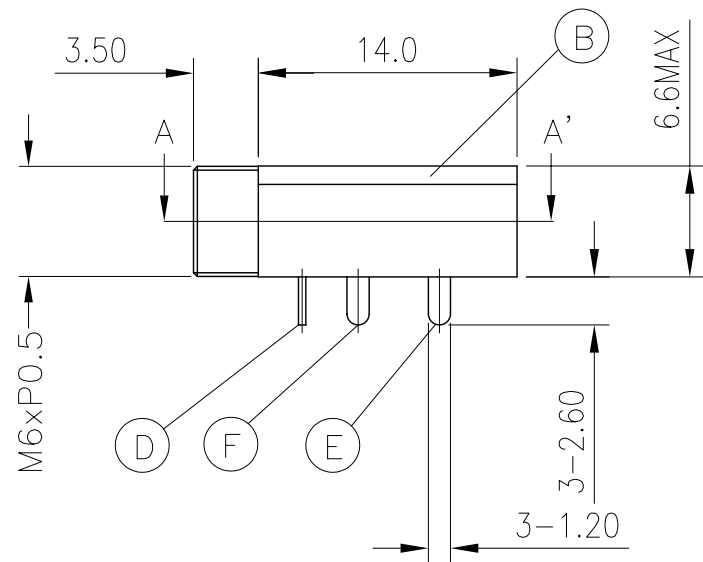
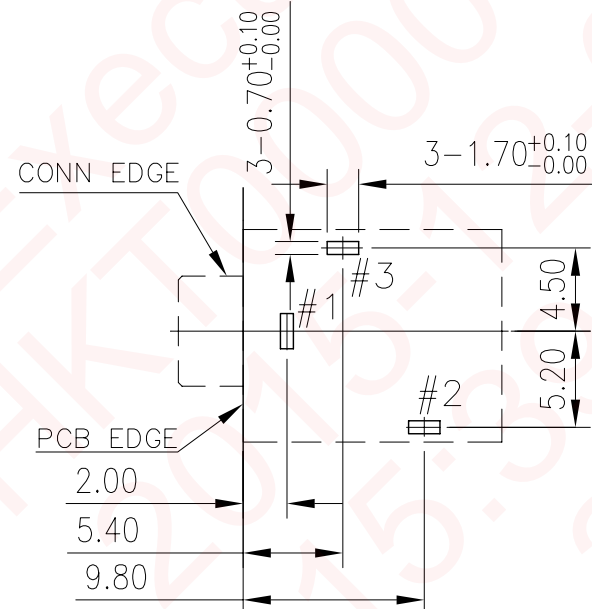
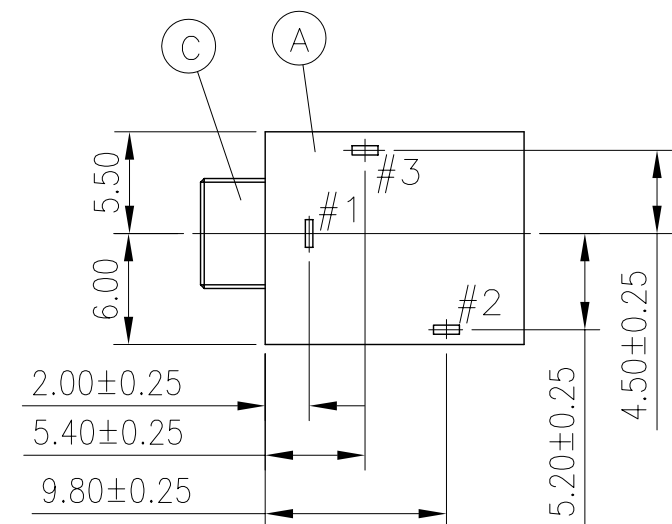

PCB LAYOUT
BOTTOM VIEW

MATING PLUG(TOLERANCE:±0.05)
Ø3.5 3-POLE STANDARD PLUG

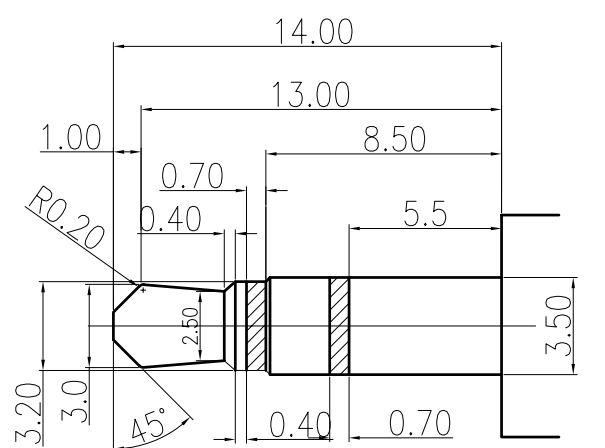

CIRCUIT:

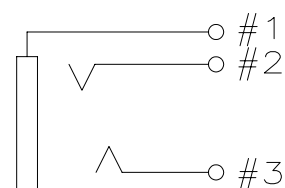

H	COIL SPRING B	1	SUS 0.25φ	N/A
G	COIL SPRING A	1	SUS 0.3φ	N/A
F	TIP SPRING	1	COPPER ALLOR 0.25t	GOLD FLASH
E	RING SPRING	1	COPPER ALLOR 0.25t	GOLD FLASH
D	EARTH TERMINAL	1	BRASS 0.4t	GOLD FLASH
C	METAL	1	BRASS	NICKEL PLATING
B	COVER	1	POLYCARBONATE TRANSPARENT UL 94V-2	
A	BODY	1	PBT UL 94V-0	BLACK COLOR

NO	DESCRIPTION	QTY	MATERIAL	PLATING & COLOR
----	-------------	-----	----------	-----------------

UNLESS OTHERWISE SPECIFIED TOLERANCES

DECIMALS:	ANGLES:
X :±0.5	X :±2°
X.X :±0.3	X.X :±1°
X.XX :±0.2	

Singatron Enterprise Co., Ltd.
信音企業股份有限公司

TITLE	3.5φ STEREO JACK		
DWN	Xinrong-Tan 15/12/07	PART NO. 2SJ-0363-001	
CHKD	Zhijun-Wei 15/12/07	SCALE 2:1	UNIT: mm
APVD	Zip-Zhou 15/12/07	SIZE: A3	SHEET:1 OF 1

CUSTOMER COPY