

REV.	ECN NO OR DESCRIPTION	REVISED	DATE
B	料號變更・ECN NO.:7000047	KENSON	8/25/09

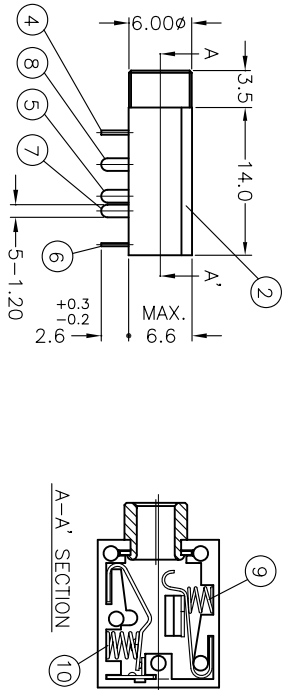

- SPECIFICATION:
- CONTACT RESISTANCE: 20 m MAX.
 - INSULATION RESISTANCE: 100 M MIN. AT 250V DC.
 - DIELECTRIC STRENGTH: 250V AC 1 MINUTE.
 - LIFE TEST:
JACK SHALL WITHSTAND 5000 CYCLES OF INSERTION AND WITHDRAWAL WITH TESTING PLUG, AFTER TEST THE CONTACT RESISTANCE SHALL NOT EXCEED 0.1
 - MEASURING CONDITION:
TEMPERATURE: FROM 5°C TO 35°C
RELATIVE HUMIDITY: FROM 40% TO 85%
 - INSERTION FORCE: 0.4kg~1.6kg.
 - WITHDRAWAL FORCE: 0.4kg~1.4kg.

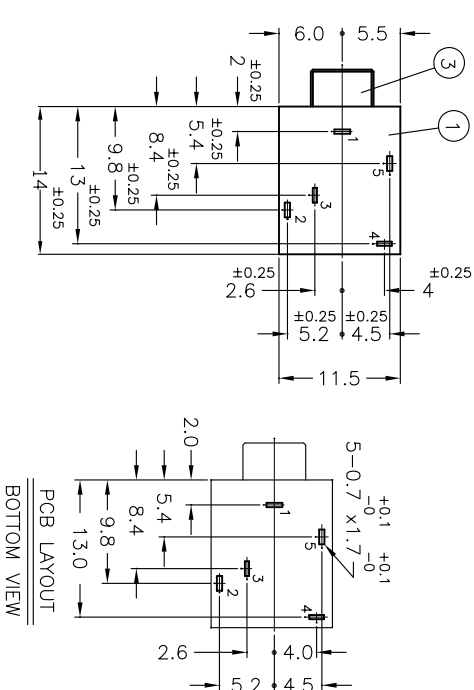
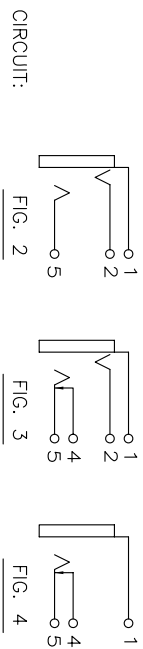

"TABLE 1" A

DRAWING	CIRCUIT FIG.	TIP SPRING	RING SPRING	CONTACTOR A	CONTACTOR B
2SJ-03633D23	FIG. 2	1	1		
2SJ-03643D23	FIG. 3	1	1		
2SJ-03653D23	FIG. 4	1			

10	COIL SPRING B	1	SUS 0.30	
9	COIL SPRING A	1	SUS 0.250	
8	TIP SPRING	*	BRASS 0.3t	SILVER PLATING
7	RING SPRING	*	PHOSPHOR BRONZE 0.25t	SILVER PLATING
6	CONTACT B	*	BRASS 0.3t	SILVER PLATING
5	CONTACT A	*	BRASS 0.3t	SILVER PLATING
4	EARTH TERMINAL	1	BRASS 0.4t	SILVER PLATING
3	METAL	1	BRASS	GOLD FLASH
2	COVER	1	POLYCARBONATE TRANSPARENT UL 94V-2	
1	BODY	1	PBT UL 94V-0	BLACK COLOR
NO	DESCRIPTION	QTY	MATERIAL	PLATING & COLOR

UNLESS OTHERWISE SPECIFIED TOLERANCES

DECIMALS: ANGLES:

X : ±0.5 X : ±2°
 X.X : ±0.3 X.X : ±1°
 X.XX : ±0.2

Singtron Electronic(Chung-Shan) Co., Ltd.
 信晉電子(中山)有限公司

3.50mm STEREO JACK

TITLE	PART NO.	UNIT	REV.
DWN	KENSON 8/25/09	2SJ-036	3D23
CHKD	HARVEY 8/25/09	SCALE:1:1	mm
APVD	ROBIN 8/25/09	SIZE: A3	SHEET: 10F1

CUSTOMER COPY