

REV.	ECN NO OR DESCRIPTION	REVISED	DATE
C	ECN NO: 920008	EVEN	2006.2.6
D	ADD DATE CODE	HAIHUA	7/30'07

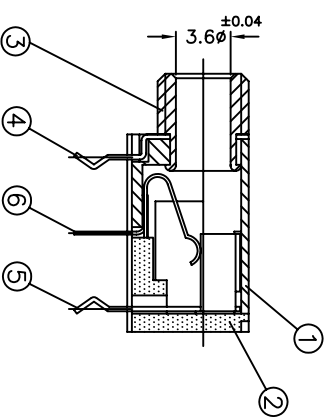

- SPECIFICATION:
- CONTACT RESISTANCE: 30 mΩ MAX.
 - INSULATION RESISTANCE: 100 MΩ MIN. AT 250V DC.
 - DIELECTRIC STRENGTH: 250V AC 1 MINUTE.
 - LIFE TEST:
JACK SHALL WITHSTAND 5000 CYCLES OF INSERTION AND WITHDRAWAL WITH TESTING PLUG, AFTER TEST THE CONTACT RESISTANCE SHALL NOT EXCEED 0.1
 - MEASURING CONDITION:
TEMPERATURE: FROM 5°C TO 35°C
RELATIVE HUMIDITY: FROM 40% TO 85%
 - ELECTRICAL CIRCUIT:

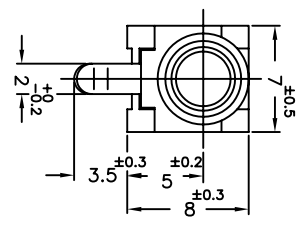
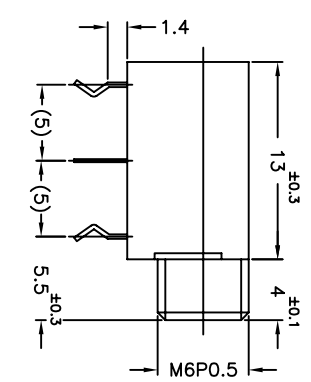
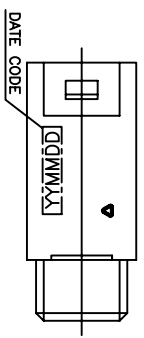
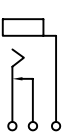

- INSERTION FORCE: 0.4Kg~1.6Kg.
- WITHDRAWAL FORCE: 0.4Kg~1.6Kg.
- SOLDER HEAT RESISTANCE: WAVE SOLDERING 260°C 10SECS.
- TO CONFORM TO THE "SE-01-001" & "ROHS DIRECTIVE"
- GREEN PRODUCT IDENTIFICATION MARK IN JACK:
- GREEN PRODUCT IDENTIFICATION LABEL IN PACKING:
- FOR WAVE SOLDERING LEAD-FREE PROCESS.
- PRINTED DATE CODE "YYMMDD" ON TOP OF CONNECTOR.

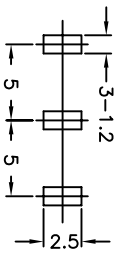
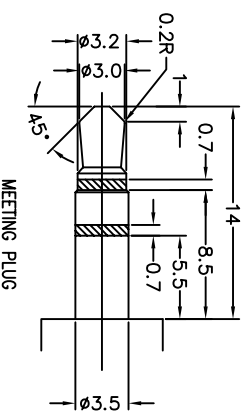
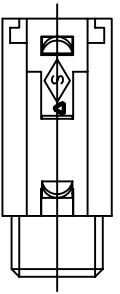
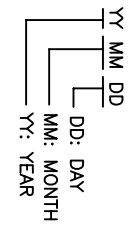

6	TERMINAL	1	TI-CU ALLOY 0.2T	SILVER PLATING
5	SHUNT TERMINAL	1	BRASS 0.3t	SILVER PLATING
4	EARTH TERMINAL	1	BRASS 0.3t	SILVER PLATING
3	METAL	1	BRASS	NICKEL PLATING
2	COVER	1	PBT UL 94V-0	BLACK COLOR
1	BODY	1	PBT UL 94V-0	BLACK COLOR
NO	DESCRIPTION		MATERIAL	PLATING&COLOR

UNLESS OTHERWISE SPECIFIED TOLERANCES

DECIMALS:	ANGLES:
X : ±0.5	X : ±2°
XX : ±0.3	XX : ±1°
XXX : ±0.2	

TITLE	3.5φ EARPHONE JACK		
DRAWN	HAIHUA	PART NO.	2SJ-03702723
CHKD	MUYUAN	SCALE:	N/A
APVD	SENA	UNIT:	mm
	7/30'07	SIZE:	A4
		SHEET:	10F1
		REV:	D

CUSTOMER COPY

Singtong Electronic(Chung-Shan) Co., Ltd.
信通電子(中山)有限公司