

REV. ECN NO. OR DESCRIPTION	REVISED	DATE
A PRODUCT RELEASE	ARES	2012.01.13

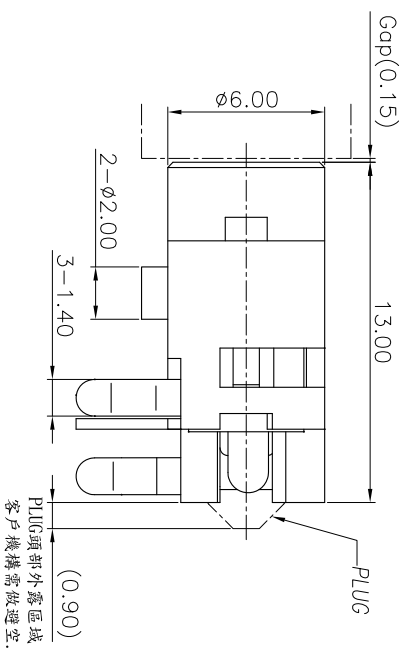

- SPECIFICATIONS:
- ELECTRICAL CHARACTERISTICS:
 - RATING: 12V 1A
 - CONTACT RESISTANCE: 30mΩ MAX (INITIAL)
 - DILECTRIC WITHSTANDING VOLTAGE: 500V AC FOR ONE MINUTE.
 - INSULATION RESISTANCE: 100MΩ MIN. MEASURED BY 500 VDC
 - MECHANICAL CHARACTERISTICS:
 - INSERTION FORCE : 3.0 Kgf Max.
 - WITHDRAWAL FORCE : 0.3 Kgf Min.
 - LIFE TEST: 5,000 CYCLES .
 - OTHER GENERAL SPEC. TO REFER "GENERAL SPEC."
 - TO CONFORM TO SINGATRON HAZARDOUS SUBSTANCE FREE SPEC.
 - HALOGEN FREE PRODUCT IDENTIFICATION MARK: ◎
 - HALOGEN FREE PRODUCT IDENTIFICATION LABEL ON PACKAGING.
 - FOR REFLOW SOLDERING LEAD-FREE PROCESS.
 - PACKAGING: TAPE & REEL.

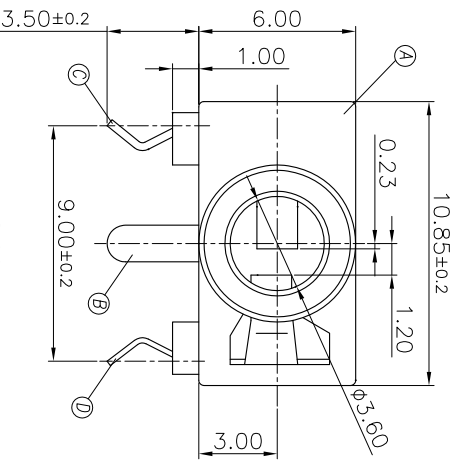
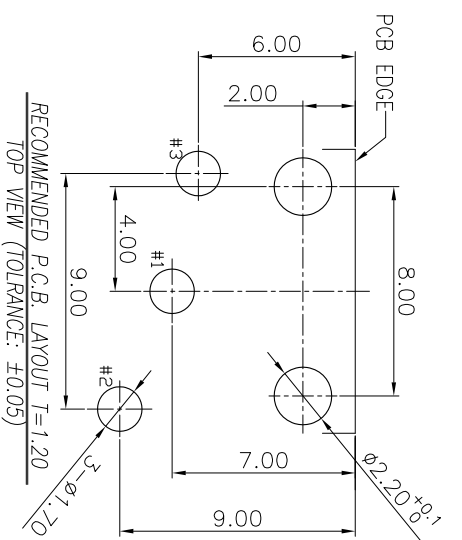
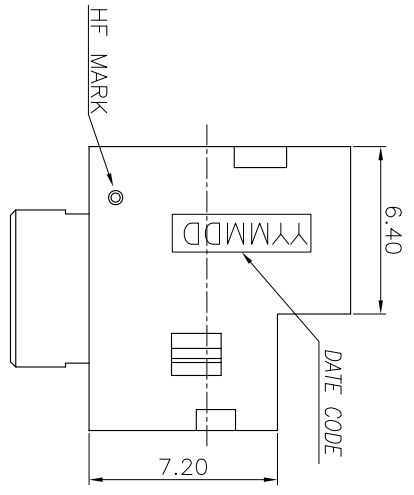
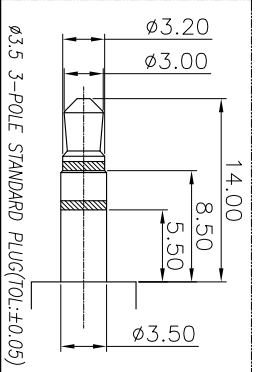
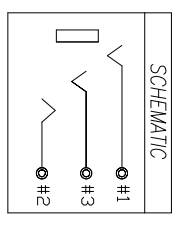
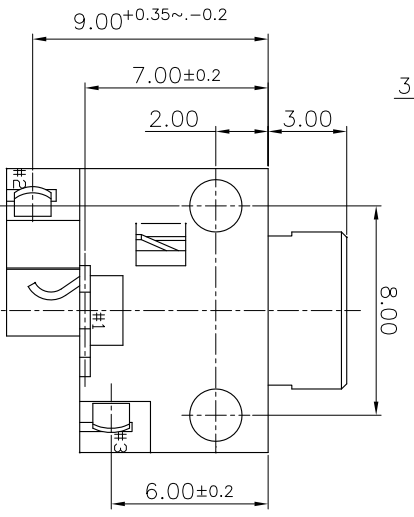

NO	DESCRIPTION	QTY	MATERIAL	PLATING & COLOR
D	RING TERMINAL	1	COPPER ALLOY 0.20t	GOLD FLASH
C	TIP TERMINAL	1	COPPER ALLOY 0.30t	GOLD FLASH
B	EARTH TERMINAL	1	COPPER ALLOY 0.40t	GOLD FLASH
A	BODY	1	HIGH TEMP THERMO PLASTIC UL94-V0	PINK (701C)

UNLESS OTHERWISE SPECIFIED TOLERANCES

Singatron Enterprise Co., Ltd.
信亨企業股份有限公司

DECIMALS:	ANGLES:	TITLE	Ø3.5 PHONE JACK
X : ±0.5	X : ±2°	DWN	PART NO. 2SJ-0380-A06F
X.X : ±0.3	X.X : ±1°	CHKD	SCALE 5:1
X.XX : ±0.2		APVD	UNIT: mm
		L110	SIZE: A3
		2020/01/16	SHEET: 10F1
		2020/01/16	REV: A

CUSTOMER COPY