

REV.	ECN NO OR DESCRIPTION	REVISED	DATE
B	修正顏色名稱 [1]	EVEN	2004.4.1
C	ECN NO.920008	JERRY	2006.6.8
D	[2] 新增一款回路	SKY	6/24'06

CIRCUIT:

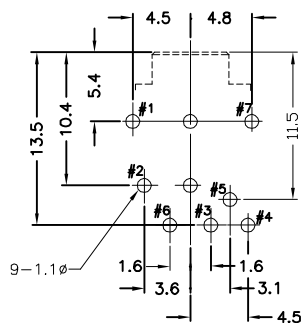

RECOMMENDED P.C.B LAYOUT
TOP VIEW
(TOLERANCE: ±0.05)

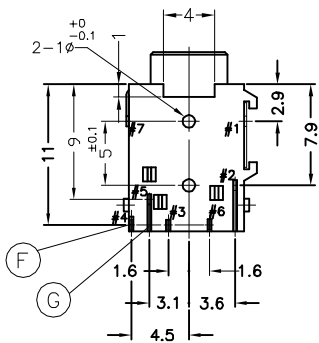
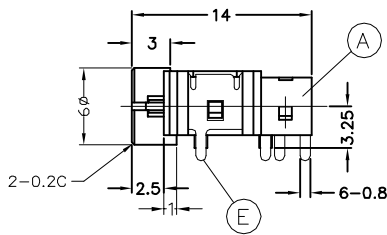
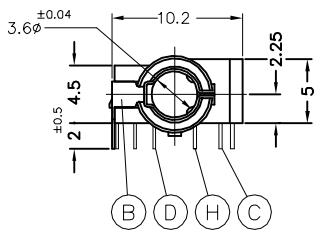
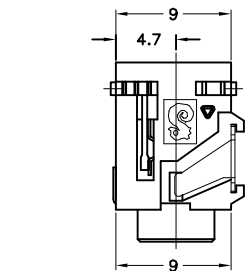
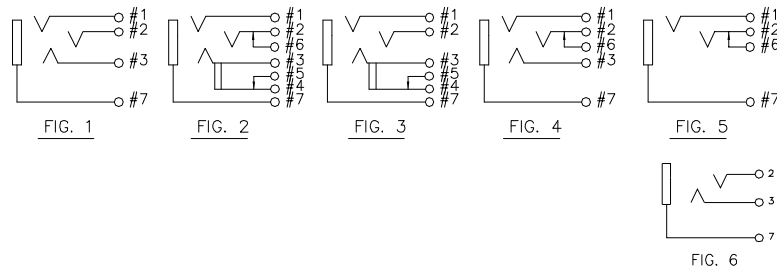
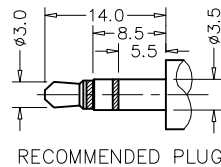

SPECIFICATIONS :

- INSULATION RESISTANCE BETWEEN ANY ADJACENT OPEN CIRCUIT TERMINAL SHELL NOT BE LESS THAN 100MΩ MEASURED BY 500 VDC MEGGER.
- CONTACT RESISTANCE : 30mΩ MAX.
- INSULATION VOLTAGE WITHSTAND : JACK SHALL WITHSTAND 500V AC BETWEEN ANY ADJACENT TERMINAL FOR ONE MINUTE.
- UNLESS OTHERWISE SPECIFIED. TEST IS TO BE MADE AT 5-35°C IN TEMPERATURE AND 45-85% IN HUMIDITY. BUT,IF ANY VAGUE DATA IS OCCURED ON TEST RESULT, ANOTHER TEST SHALL BE MADE AT 20°C±2°C IN TEMP., 60-70% IN HUMIDITY.
- LIFE TEST : 5,000 CYCLES MIN. (NON-LOAD)
- INSERTION FORCE : 0.4 - 2Kg.
- WITHDRAWAL FORCE : 0.3 - 2Kg.
- AFTER LIFE TEST, CONTACT RESISTANCE: 80mΩ MAX.
- AFTER HUMIDITY TEST, INSULATION RESISTANCE : 50MΩ MIN.
- MARKING: MARK "S" ON TOP OF CONNECTOR.
- *: SEE "TABLE 1"
- SOLDER HEAT RESISTANCE: WAVE SOLDERING 260°C 10 SECS.
- TO CONFORM TO THE "SE-01-001" & "ROHS DIRECTIVE"
- GREEN PRODUCT IDENTIFICATION MARK IN JACK:
- GREEN PRODUCT IDENTIFICATION LABEL IN PACKING: **G.P. PASS**
- FOR WAVE SOLDERING LEAD-FREE PROCESS.

NO	DESCRIPTION	QTY	MATERIAL	PLATING & COLOR
H	SHUNT TERMINAL	1	BRASS 0.25t	TIN(Lead Free)PLATING
G	BREAK TERMINAL	1	BRASS 0.2t	TIN(Lead Free)PLATING
F	TRANSFER TERMINAL	1	PHOSPHOR BRONZE 0.2t	TIN(Lead Free)PLATING
E	RING SPRING B	1	PHOSPHOR BRONZE 0.3t	TIN(Lead Free)PLATING
D	RING SPRING A	1	PHOSPHOR BRONZE 0.2t	TIN(Lead Free)PLATING
C	TIP SPRING	1	COPPER ALLOY 0.25t	TIN(Lead Free)PLATING
B	EARTH SPRING	1	PHOSPHOR BRONZE 0.2t	GOLD FLASH
A	BODY	1	NYLON-66 UL 94V-0	LIME COLOR(577C)

UNLESS OTHERWISE SPECIFIED TOLERANCES		SINGATRON ENTERPRISE CO., LTD. 信音電子(中山)有限公司			
DECIMALS:	ANGLES:	TITLE	3.5φ PHONE JACK		
X : ±0.5	X : ±2°	DWN	SKY	PART NO. 2SJ-083□-002	
X.X : ±0.3	X.X : ±1°	CHKD	SCALE: 3/1	UNIT: mm	
X.XX : ±0.2		APVD	SEAN	SIZE: A3	SHEET: 1 OF 1
CUSTOMER COPY					

"TABLE 1"

DRAWING (NEW NO.)	CIRCUIT	① RING SPRING B	② TIP SPRING	③ RING SPRING A	④ TRANSFER TERMINAL	⑤ BREAK TERMINAL	⑥ SHUNT TERMINAL	⑦ EARTH SPRING
2SJ-0830-002	FIG. 1	1	1	1				1
2SJ-0831-002	FIG. 2	1	1	1	1	1	1	1
2SJ-0832-002	FIG. 3	1	1	1	1	1		1
2SJ-0833-002	FIG. 4	1	1	1			1	1
2SJ-0834-002	FIG. 5	1	1				1	1
2SJ-0835-002	FIG. 6		1	1				1