

REV.	ECN NO OR DESCRIPTION	REVISED	DATE
E	ECN NO.: T0900047	KENSON	8/27'09
F	ECN NO.: T0900047 此產品之規格由 4373/4/5-002 改為 R-ジュ・マユ7ヨニ対応 437X-002	HAODU	2010.5.21
G	ECN NO.: C100609 MODIFY MATERIAL	LONGJIANG	2010.12.23

SPECIFICATIONS :

- ELECTRICAL REQUIREMENTS :
 - CURRENT CARRYING RATING : 24V DC 2AMP MAX.
 - CONTACT RESISTANCE :
 - 1.2.1 INITIAL (BEFORE ANY TESTING) : 20 MILLIOHMS MAX.
 - 1.2.2 AFTER 500 CYCLES TEST : 50 MILLIOHMS MAX.
 - INSULATION RESISTANCE : 50 MEGOHMS MIN. AT 500V DC.
 - DIELECTRIC WITHSTANDING VOLTAHE : 250V AC FOR 1 MINUTE.
- MECHANICAL REQUIREMENTS :
 - INSERTION FORCE : 0.4KG - 1.6KG
 - WITHDRAWAL FORCE : 0.4KG - 1.4KG
 - MECHANICAL LIFE CYCLES : AFTER 5,000 CYCLES WITHOUT BREAKDOWN.
- SOLDER HEAT RESISTANCE : WAVE SOLDERING 260°C 10SECS.
- TO CONFORM TO SINGATRON HAZARDOUS SUBSTANCE FREE SPEC.
- GREEN PRODUCT IDENTIFICATION MARK ON JACK:
- GREEN PRODUCT IDENTIFICATION LABEL ON PACKING: **G.P. PASS**
- FOR LEAD-FREE PROCESS.
- PRINTED DATE CODE "YYMMDD" ON TOP OF CONNECTOR.

DATE CODE: YYMMDD

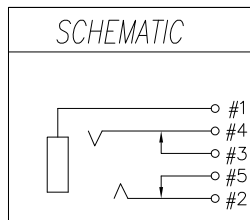
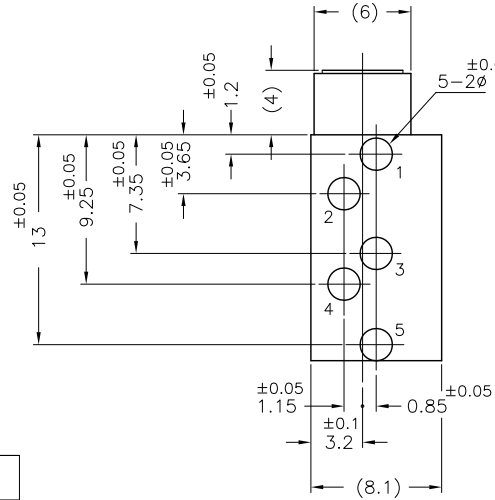
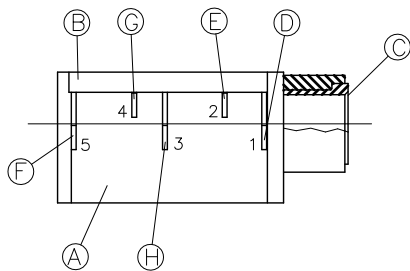
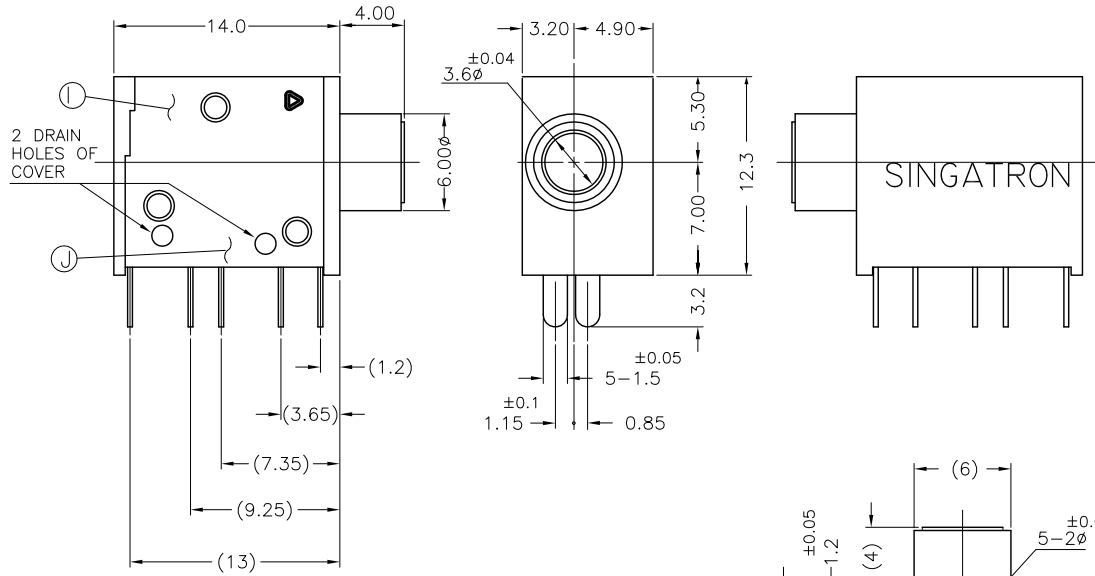
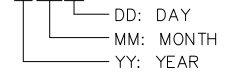

NO	DESCRIPTION	QTY	MATERIAL	PLATING & COLOR
J	COIL SPRING-B	1	SUS	N/A
I	COIL SPRING-A	1	SUS	N/A
H	SHUNT TERMINAL-B	1	BRASS 0.3t	SILVER PLATING
G	RING SPRING	1	BRASS 0.25t	SILVER PLATING
F	SHUNT TERMINAL-A	1	BRASS 0.3t	SILVER PLATING
E	TIP SPRING	1	BRASS 0.3t	SILVER PLATING
D	EARTH TERMINAL	1	BRASS 0.3t	SILVER PLATING
C	METAL	1	BRASS	NICKEL PLATING
B	COVER	1	THERMOPLASTIC UL 94V-0	TRANSPARENT
A	BODY	1	THERMOPLASTIC UL 94V-0	LIGHT BLUE COLOR(PAN.#284C)

UNLESS OTHERWISE SPECIFIED TOLERANCES		Singatron Enterprise Co., Ltd. 信音企業股份有限公司	
DECIMALS:	ANGLES:	TITLE	3.5 PHONE JACK
X : ±0.5	X : ±2°	DWN	Longjiang 11.01.03 PART NO. 2SJ-4372-002
X.X : ±0.3	X.X : ±1°	CHKD	ZAZ 11.01.03 SCALE 3:1 UNIT: mm
X.XX : ±0.2		APVD	Liao 11.01.03 SIZE: A3 SHEET: 10F1 REV: G
CUSTOMER COPY			