

REV.	ECN NO OR DESCRIPTION	REVISED	DATE
B	SERIES APPROVED 2SJ-A001-003	Beryl	2004-12-6
C	ECN NO: 940049	EVEN	2005.3.16

SPECIFICATIONS :

- 1.SEE 2SJ-A373-001 SPECIFICATIONS.
- 2.PACKING: TAPE & REEL
- 3.SOLDERING CONDITION: WAVE SOLDERING.
- 4.TO CONFORM TO THE "SE-01-001" & "THE EUROPEAN RESTRICTIONS-ON HAZARDOUS SUBSTANCES (ROHS) DIRECTIVE"
- 5.GREEN PRODUCT IDENTIFICATION LABEL IN PACKING: **G.P. PASS**
- 6.FOR LEAD FREE PROCESS

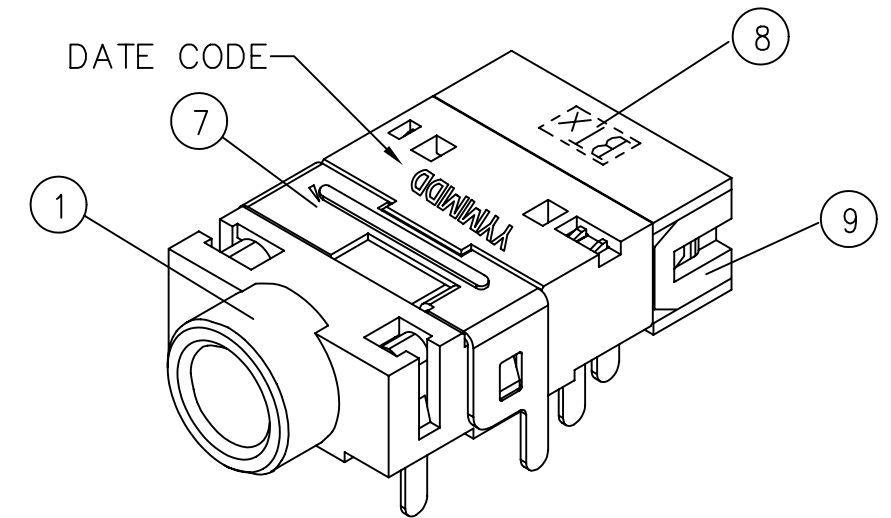
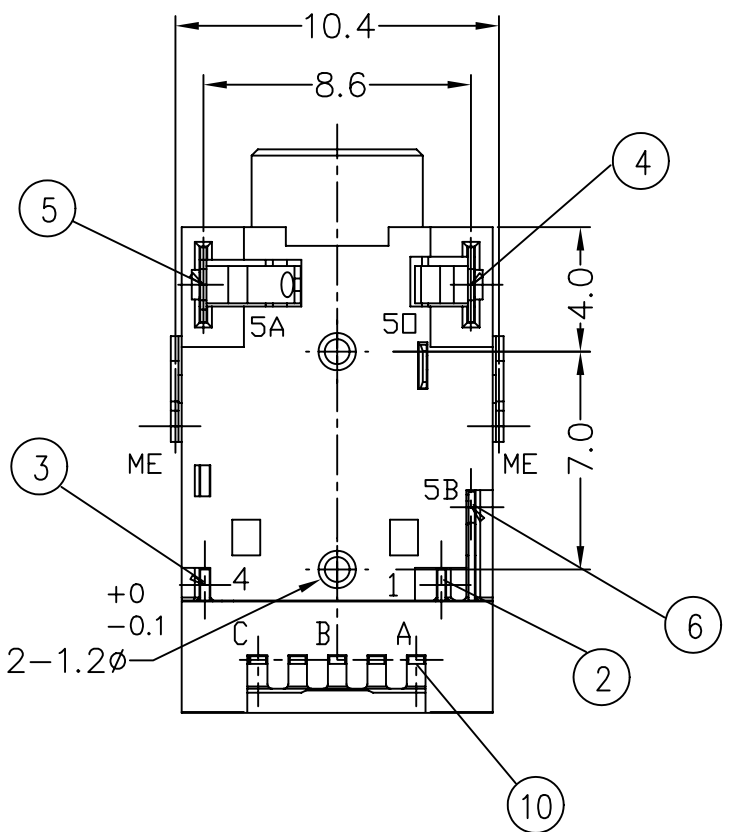
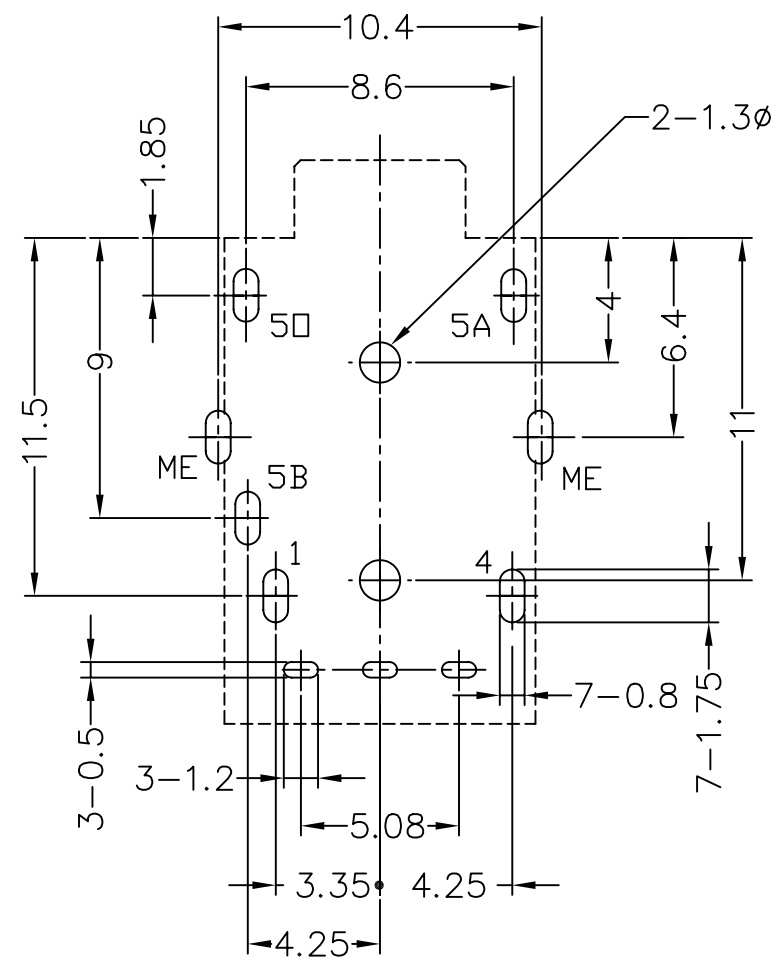
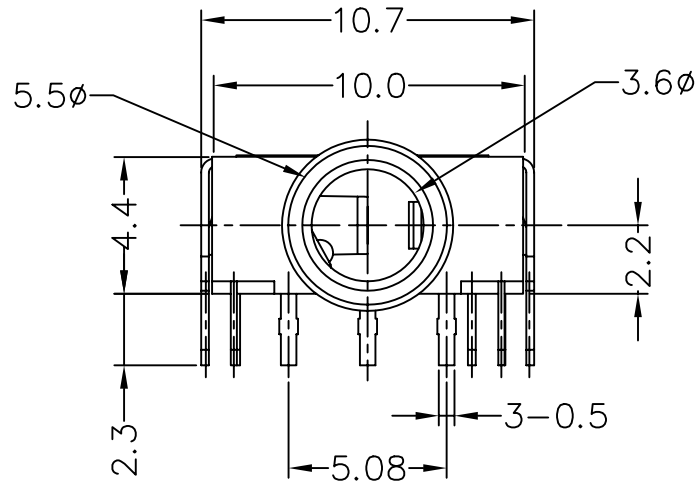
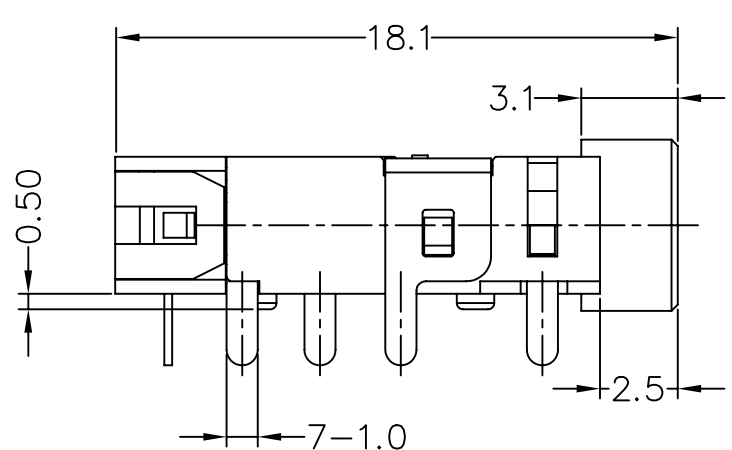

RECOMMENDED PCB LAYOUT  
COMPONENT SIDE  
(TOLERANCE: ±0.05)

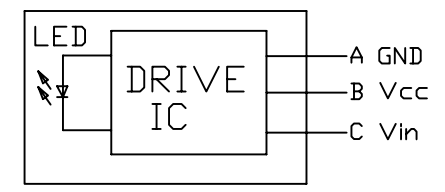
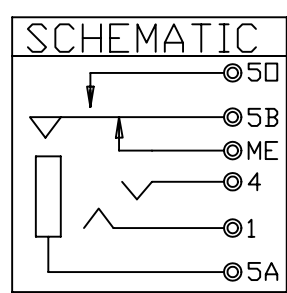

"TABLE 1"

PART NO	HOUSING COLOR
2SJ-A001-002	LIME(577C)
2SJ-A001-003	BLACK

NO	DESCRIPTION	QTY	MATERIAL	PLATING & COLOR
10	IC DRIVE	1		
9	COVER	1	PA-9T UL 94V-0	BLACK COLOR
8	CASE	1	PA-9T UL 94V-0	BLACK COLOR
7	SHELL	1	PHOSPHOR BRONZE 0.25t	GOLD FLASH
6	EARTH	1	PHOSPHOR BRONZE 0.25t	GOLD FLASH
5	EARTH SPRING B	1	PHOSPHOR BRONZE 0.2t	GOLD FLASH
4	EARTH SPRING A	1	PHOSPHOR BRONZE 0.3t	GOLD FLASH
3	TIP SPRING	1	PHOSPHOR BRONZE 0.2t	GOLD FLASH
2	RING SPRING	1	PHOSPHOR BRONZE 0.25t	GOLD FLASH
1	BODY	1	PA-9T UL 94V-0	SEE 'TABLE 1"

UNLESS OTHERWISE SPECIFIED TOLERANCES

Singatron Enterprise Co., Ltd.  
信音企業股份有限公司

DECIMALS: ANGLES:  
X :±0.3 X :±2°  
X.X :±0.2 X.X :±1°  
X.XX :±0.1

TITLE	3.5φ PHONE JACK		
DWN	EVEN 2005/3/16	PART NO. 2SJ-A001-00□	
CHKD	KAN 2005/3/16	SCALE:4/1	UNIT: MM
APVD	ALAN 2005/3/16	SIZE: A3	SHEET:1 OF 1 REV: C