

REV.	ECN NO OR DESCRIPTION	REVISED	DATE
A	PDR NO.:T080908-3A	Sidney	2008.09.08
B	ECN NO.T080204	LILI	2008.12.29
C	ECN NO.:S090235	Bruce	2009.03.27

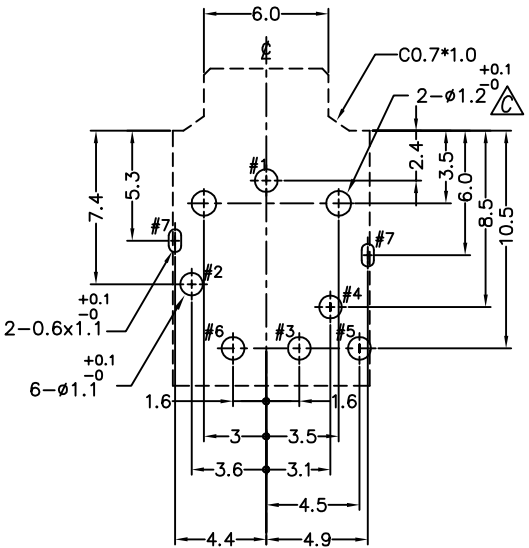

RECOMMENDED PCB LAYOUT
TOP VIEW(TOL.±0.05)

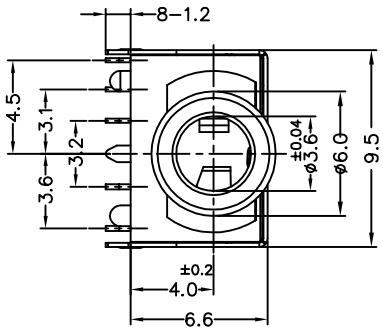
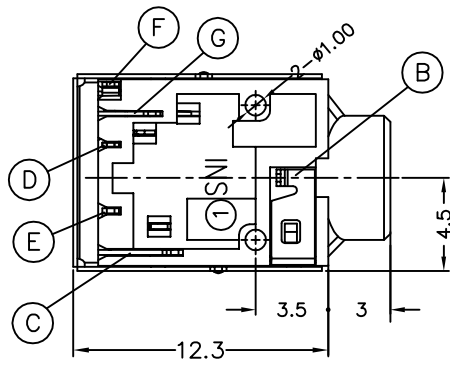
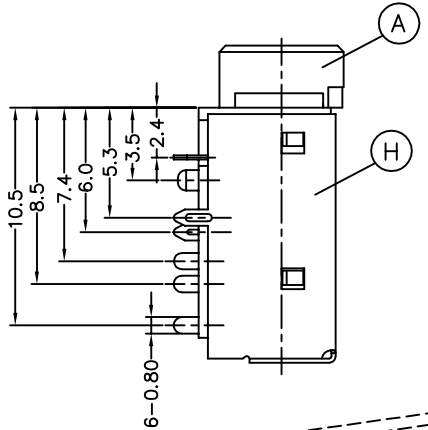

FOR COMPAL

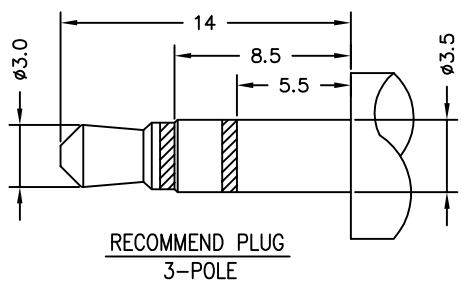

RECOMMEND PLUG
3-POLE

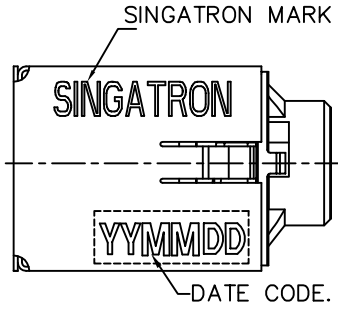
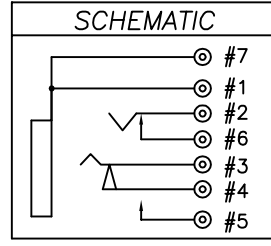

- SPECIFICATIONS:
- INSULATION RESISTANCE BETWEEN ANY ADJACENT OPEN CIRCUIT TERMINAL SHELL NOT BE LESS THAN 100MΩ MEASURED BY 500 VDC MEGGER.
 - CONTACT RESISTANCE: 30mΩ MAX.
 - INSULATION VOLTAGE WITHSTAND: 500V AC FOR ONE MINUTE.
 - UNLESS OTHERWISE SPECIFIED. TEST IS TO BE MADE AT 5-35°C IN TEMPERATURE AND 45-85% IN HUMIDITY. BUT,IF ANY VAGUE DATA IS OCCURED ON TEST RESULT, ANOTHER TEST SHALL BE MADE AT 20°C±2°C IN TEMP., 60-70% IN HUMIDITY.
 - LIFE TEST: 5,000 CYCLES MIN. (NON-LOAD)
 - INSERTION FORCE :0.4 - 3Kg.
 - WITHDRAWAL FORCE :0.3 - 2Kg.
 - AFTER LIFE TEST, CONTACT RESISTANCE: 50mΩ MAX.
 - AFTER HUMIDITY TEST, INSULATION RESISTANCE :50MΩ MIN.
 - METAL,EARTH AND SHIELDING MUST BE CONDUCT.
 - MARKING: MARK "S" ON TOP OF CONNECTOR.
 - PACKAGING : TAPE & REEL.
 - TO CONFORM TO SINGATRON HAZARDOUS SUBSTANCE FREE SPEC.
 - HALOGEN FREE PRODUCT IDENTIFICATION MARK ON PRODUCT.
 - HALOGEN FREE PRODUCT IDENTIFICATION LOGO ON PACKING.
 - FOR LEAD-FREE PROCESS.

NO	DESCRIPTION	QTY	MATERIAL	PLATING & COLOR
H	SHIELDING	1	PHOSPHOR BRONZE 0.2t	Ni 60u"Min
G	TRANSFER TERMINAL	1	PHOSPHOR BRONZE 0.2t	Ag 20u"Min OVER Ni 20u" Min.
F	BREAK TERMINAL	1	PHOSPHOR BRONZE 0.2t	Ag 20u"Min OVER Ni 20u" Min.
E	SHUNT TERMINAL-A	1	BRASS 0.25t	Ag 20u"Min OVER Ni 20u" Min.
D	RING SPRING	1	PHOSPHOR BRONZE 0.2t	Ag 20u"Min OVER Ni 20u" Min.
C	TIP SPRING	1	PHOSPHOR BRONZE 0.25t	Ag 20u"Min OVER Ni 20u" Min.
B	EARTH	1	PHOSPHOR BRONZE 0.2t	Ag 20u"Min OVER Ni 20u" Min.
A	BODY	1	HIGH TEMP.THERMOPLASTIC	BLACK

UNLESS OTHERWISE SPECIFIED TOLERANCES

DECIMALS: X :±0.5 X.X :±0.3 X.XX :±0.2

ANGLES: X :±2° X.X :±1°

TITLE: **φ3.5 PHONE JACK**

DWN BRUCE 2009.03.27 PART NO.:2SJ-B351-004

CHKD Lussen 2009.03.30 SCALE:4:1 UNIT: mm

APVD Max 2009.03.30 SIZE: A3 SHEET:1 OF 1 REV:C

Singatron Enterprise Co., Ltd.
信音企業股份有限公司

CUSTOMER COPY