

REV/ECN NO OR DESCRIPTION	REVISED	DATE
C ECN NO:920001	EVEN	1/27-06
D ECN NO:1060223	BERYL	2006.9.18
E ECN NO:5070520	RAY	2007.05.22

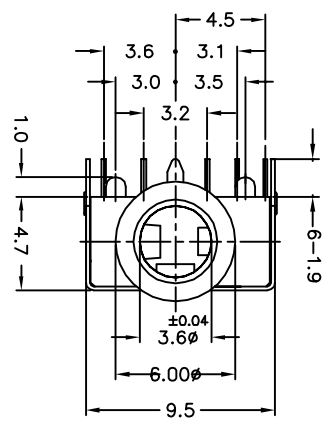

CIRCUIT:

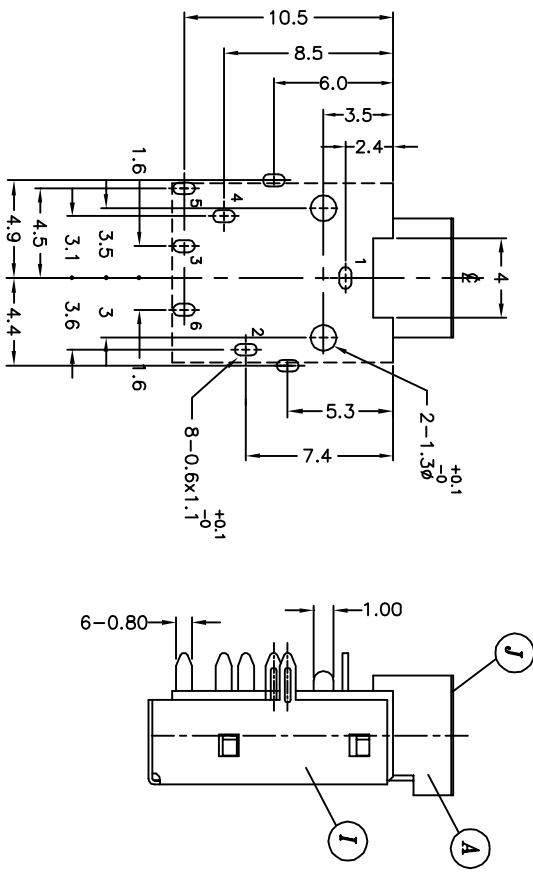
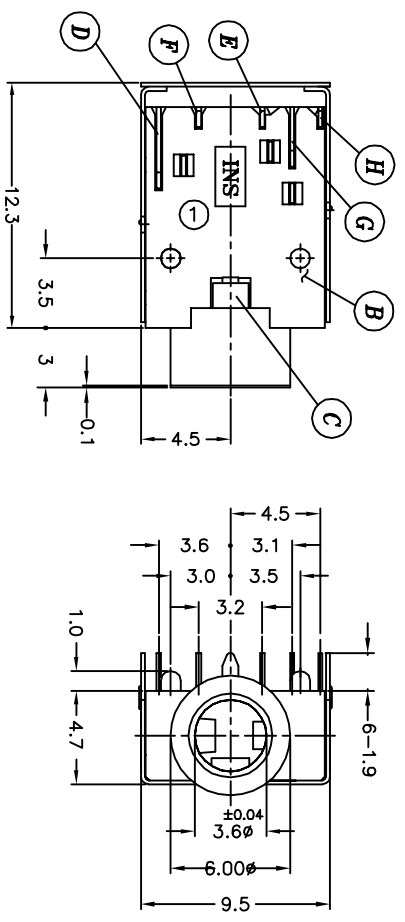
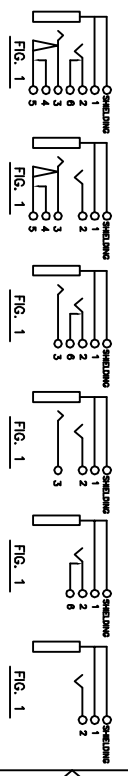

RECOMMENDED PCB LAYOUT
SOLDER SIDE
(TOLERANCE: ±0.05)

DRAWING NO.	CIRCUIT	RING SPRING	SHUNT TERMINAL A	BREAK TERMINAL	TRANSFER TERMINAL
ZSJ-C820-S46	FIG. 1	1	1	1	1
ZSJ-C821-S46	FIG. 2	1	1		
ZSJ-C822-S46	FIG. 3	1	1		1
ZSJ-C823-S46	FIG. 4	1	1		
ZSJ-C824-S46	FIG. 5			1	
ZSJ-C825-S46	FIG. 6				

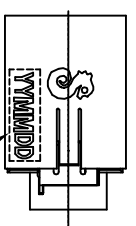

- INSULATION RESISTANCE BETWEEN ANY ADJACENT OPEN MEASURED BY 500 VDC MEGGER.
- CONTACT RESISTANCE: 30mΩ MAX. (200mΩ MAX: METAL TO EARTH TO SHIELDING)
- DIELECTRIC VOLTAGE WITHSTAND: 500V AC FOR ONE MINUTE. TEST IS TO BE MADE AT 5-35°C IN TEMPERATURE AND 45-85% IN HUMIDITY. BUT IF ANY VAGUE DATA IS OCCURED ON TEST RESULT, ANOTHER TEST SHALL BE MADE AT 20°C±2°C IN TEMP., 60-70% IN HUMIDITY.
- LIFE TEST: 5,000 CYCLES MIN. (NON-LOAD)
- INSERTION FORCE: 0.4 - 3Kg.
- WITHDRAWAL FORCE: 0.3 - 2Kg.
- AFTER LIFE TEST, CONTACT RESISTANCE: 50mΩ MAX.
- AFTER HUMIDITY TEST, INSULATION RESISTANCE: 50mΩ MIN.
- MARKING: MARK "S" ON TOP OF CONNECTOR.
- PACKING: TAPE & REEL.
- TO CONFORM TO THE "SE-01-001" & "ROHS DIRECTIVE"
- GREEN PRODUCT IDENTIFICATION MARK IN JACK: G.P. PASS
- FOR LEAD-FREE PROCESS.

NO	DESCRIPTION	QTY	MATERIAL	PLATING & COLOR
A	BODY	1	HIGH TEMP.THERMOPLASTIC UL 94V-0	PINK COLOR (PANTONE NO.701C)
B	SEPARATOR	1	UL 94V-0	BLACK COLOR
C	METAL	1	BRASS	NICKEL PLATING
D	SHIELDING	1	PHOSPHOR BRONZE 0.2t	NICKEL PLATING
E	TRANSFER TERMINAL	1	PHOSPHOR BRONZE 0.2t	SILVER PLATING
F	BREAK TERMINAL	1	BRASS 0.2t	SILVER PLATING
G	SHUNT TERMINAL-A	1	BRASS 0.25t	SILVER PLATING
H	RING SPRING	1	PHOSPHOR BRONZE 0.2t	SILVER PLATING
I	TIP SPRING	1	PHOSPHOR BRONZE 0.25t	SILVER PLATING
J	EARTH	1	COPPER ALLOY 0.3t	SILVER PLATING

UNLESS OTHERWISE SPECIFIED TOLERANCES
DECIMALS: ANGLES:
X :±0.5 X :±2°
X.X :±0.3 X.X :±1°
X.XX :±0.2

Singatron Enterprise Co., Ltd.
信音企業股份有限公司
TITLE: 3.5Φ PHONE JACK
DWG: Rev 2007.5.22 PART NO. ZSJ-C820-S46
CHKD: Lissw/2007.5.24 SCALE: 4/1 UNIT: mm
APVD: Sany/2007.5.28 SIZE: A3 SHEET: 1 OF 1 REV: E
CUSTOMER COPY