

REV.	ECN NO OR DESCRIPTION	REVISED	DATE
A	PDR NO.S180517-4A	Xinzhi	2018.05.18

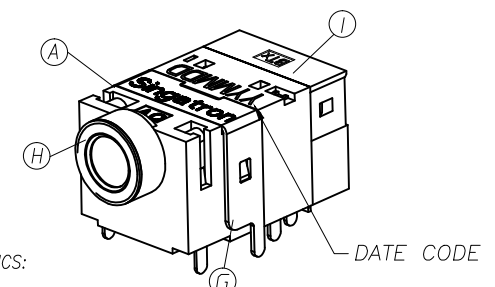

- SPECIFICATIONS:
- ELECTRICAL CHARACTERISTICS:
 - RATING: 12V 1A
 - CONTACT RESISTANCE: 30mΩ MAX.(INITIAL)
 - DIELECTRIC WITHSTANDING VOLTAGE: 500V AC FOR ONE MINUTE.
 - INSULATION RESISTANCE: 100MΩ MIN. MEASURED BY 500 VDC.
 - MECHANICAL CHARACTERISTICS:
 - INSERTION FORCE: 0.3-3.0Kgf;
 - WITHDRAWAL FORCE: INITIAL 0.4-3.0Kgf;
 - LIFE TEST: 5,000 CYCLES MIN.
AFTER LIFE TEST, CONTACT RESISTANCE: 100mΩ MAX.
 - PACKAGING : TAPE & REEL.
 - AFTER HUMIDITY TEST, INSULATION RESISTANCE: 50MΩ MIN.
 - TO CONFORM TO SINGATRON HAZARDOUS SUBSTANCE FREE SPEC.
 - HALOGEN FREE PRODUCT IDENTIFICATION MARK ON PRODUCT:
 - HALOGEN FREE PRODUCT IDENTIFICATION LOGO ON PACKAGING:
 - FOR REFLOW SOLDERING LEAD-FREE PROCESS.
 - PRINTED DATE CODE "YYMMDD-" ON TOP OF CONNECTOR.

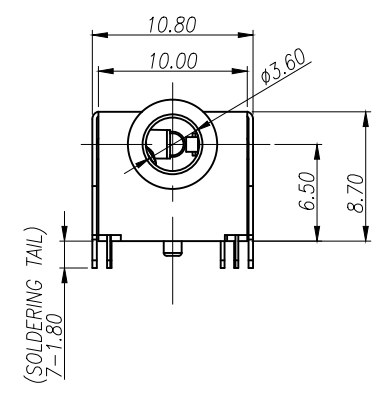
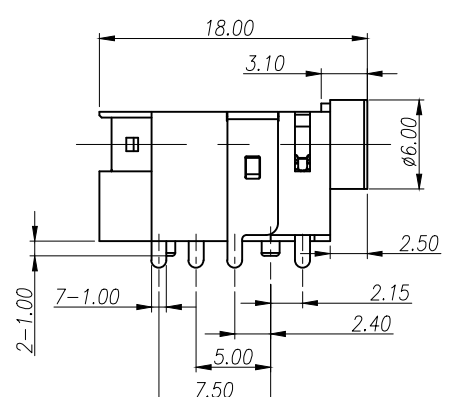
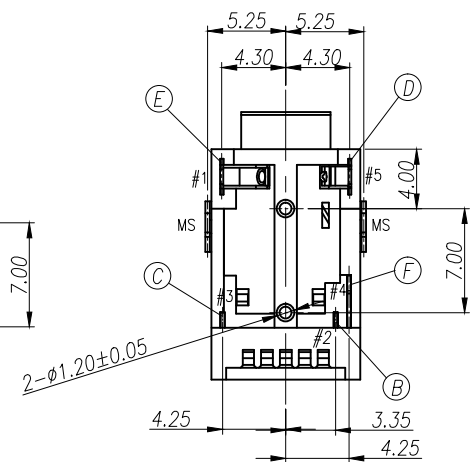
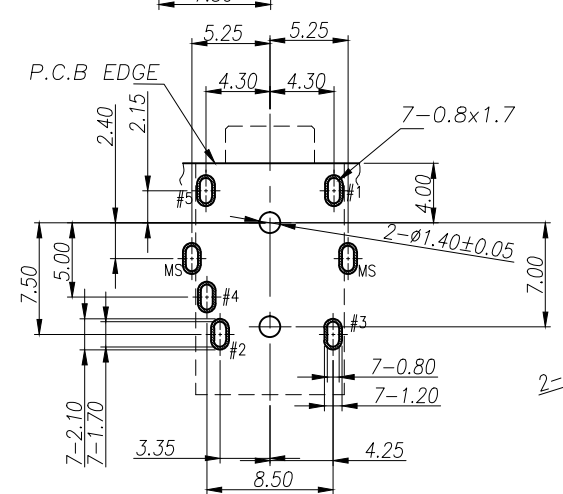

RECOMMENDED PCB LAYOUT 1.60T
SOLDER SIDE (Tolerance:±0.05)

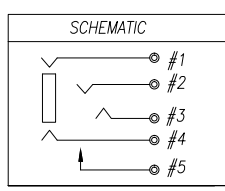
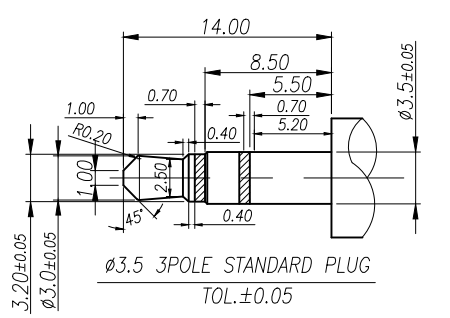

I	CASE	1	PA4T+30%GF UL 94V-0	BLACK
H	METAL	1	BRASS	OVER Ni 50u"Min. (可焊接)
G	SHIELDING	1	BRASS 0.3T	
F	EARTH SPRING-A	1	PHOSPHOR BRONZE 0.25T	GOLD FLASH OVER NI 50u" MIN.
E	EARTH SPRING-B	1	PHOSPHOR BRONZE 0.20T	
D	EARTH TERMINAL	1	PHOSPHOR BRONZE 0.20T	
C	TIP SPRING	1	PHOSPHOR BRONZE 0.25T	
B	RING SPRING	1	PHOSPHOR BRONZE 0.25T	
A	BODY	1	PA10T+30%GF R630N UL 94V-0	BLACK
NO	DESCRIPTION	QTY	MATERIAL	PLATING & COLOR
UNLESS OTHERWISE SPECIFIED TOLERANCES		Singatron Enterprise Co., Ltd. 信音企業股份有限公司		
DECIMALS:	ANGLES:	TITLE: ϕ 3.5 PHONE JACK		
X :±0.5	X :±2°	DWN	Xinzhi	PART NO.2SJ-E373-T09F
X.X :±0.3	X.X :±1°	CHKD	Bruce	SCALE 3:1 UNIT: mm
X.XX :±0.2		APVD	Liao	SIZE: A3 SHEET:1 OF 1 REV:A
CUSTOMER COPY				