

REV.	ECN NO OR DESCRIPTION	REVISED	DATE
A	PRODUCT RELEASE	Jobs	2011.01.21

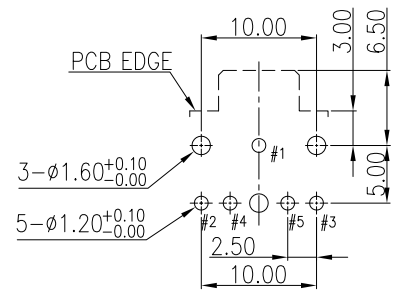

RECOMMENDED PCB LAYOUT
TOP VIEW (TOLERANCE:±0.05)

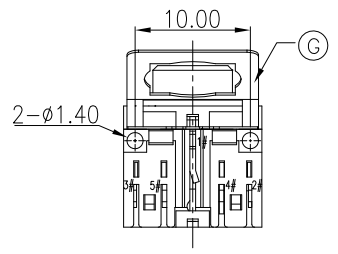
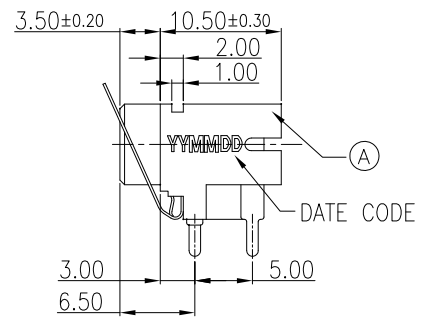
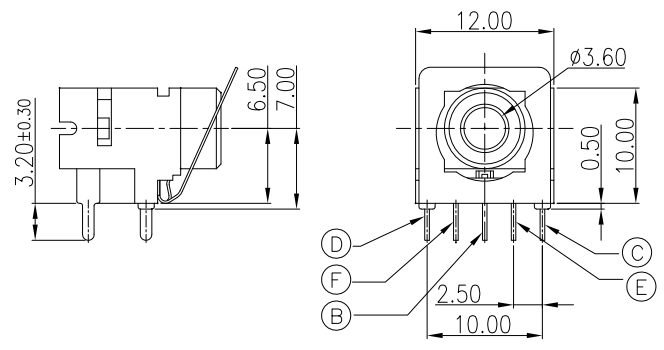
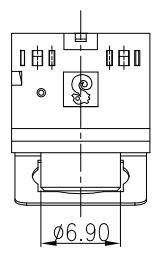
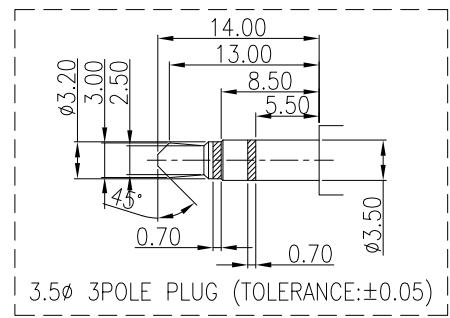
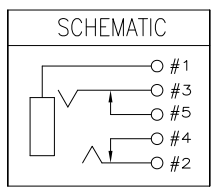

SPECIFICATIONS:

- ELECTRICAL CHARACTERISTICS:
 - RATING: 12V 1A
 - CONTACT RESISTANCE: 30mΩ MAX(BEFORE).
 - DIELECTRIC VOLTAGE WITHSTAND: 500V AC FOR ONE MINUTE
 - INSULATION RESISTANCE: 100MΩ MIN. MEASURED BY 500 VDC
- MECHANICAL CHARACTERISTICS:
 - INSERTED FORCE : 0.3~3.0 Kgf
 - WITHDRAWAL FORCE : 0.3~3.0 Kgf
- LIFE TEST: 5,000 CYCLES MIN.
- OTHER GENERAL SPEC. TO REFER "2SJ-P510 SERIES SPEC".
- TO CONFORM TO THE SINGATRON HSF SPECIFICATION.
- HALOGEN FREE PRODUCT IDENTIFICATION MARK:
- HALOGEN FREE PRODUCT IDENTIFICATION LABEL ON PACKAGING:
- FOR WAVE SOLDERING LEAD-FREE PROCESS.
- PACKAGING:TRAY.

G	GROUNDING SPRING	1	STAINLESS STEEL 0.2t	
F	SHUNT TERMINA-B	1	BRASS 0.4t	SILVER PLATING
E	SHUNT TERMINA-A	1	BRASS 0.4t	SILVER PLATING
D	RING SPRING	1	COPPER ALLOY 0.25t	SILVER PLATING
C	TIP SPRING	1	COPPER ALLOY 0.3t	SILVER PLATING
B	EARTH TERMINAL	1	BRASS 0.5t	SILVER PLATING
A	BODY	1	PBT UL 94V-0	LIME(577C)
NO	DESCRIPTION	QTY	MATERIAL	PLATING & COLOR

UNLESS OTHERWISE SPECIFIED TOLERANCES

Singatron Enterprise Co., Ltd.
信音企業股份有限公司

DECIMALS:	ANGLES:	TITLE	3.5φ PHONE JACK		
X : ±0.5	X : ±2°	DWN	Jobs 11.01.25	PART NO. 2SJ-P510-004F	
X.X : ±0.3	X.X : ±1°	CHKD	Winkan 11.01.25	SCALE: 5:1	UNIT: mm
X.XX : ±0.2		APVD	Liao 11.01.25	SIZE: A3	SHEET: 10F1
					REV: A

CUSTOMER COPY