

REV.	ECN NO.	OR DESCRIPTION	REVISED	DATE
A		ADD SILVER PLATING THICKNESS	WeiJie Zeng	2017.07.06

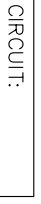

- SPECIFICATIONS:
- ELECTRICAL CHARACTERISTICS:
    - CONTACT RESISTANCE: 30mΩ MAX.(INITIAL)
    - DIELECTRIC WITHSTANDING VOLTAGE: 250V AC FOR ONE MINUTE.
    - INSULATION RESISTANCE: 50MΩ MIN. MEASURED BY 250V DC.
  - MECHANICAL CHARACTERISTICS:
    - INSERTION FORCE: 0.3KG ~ 2.5KG.
    - WITHDRAWAL FORCE: 0.3KG ~ 2.5KG.
    - LIFE TEST: 5,000 CYCLES.
  - ENVIRONMENTAL CHARACTERISTICS:
    - MEASURING CONDITIONS:
      - TEMPERATURE: FROM 5°C TO 40°C.
      - RELATIVE HUMIDITY: FROM 40% TO 85%
  - SOLDER HEAT RESISTANCE: WAVE SOLDERING 260°C 10 SECS.
  - TO CONFORM TO SINGATRON HAZARDOUS SUBSTANCE FREE SPEC.
  - GREEN PRODUCT IDENTIFICATION MARK IN JACK:
  - GREEN PRODUCT IDENTIFICATION LABEL IN PACKING:
  - FOR WAVE SOLDERING LEAD-FREE PROCESS.
  - PRINTED DATE CODE " " ON TOP OF CONNECTOR.

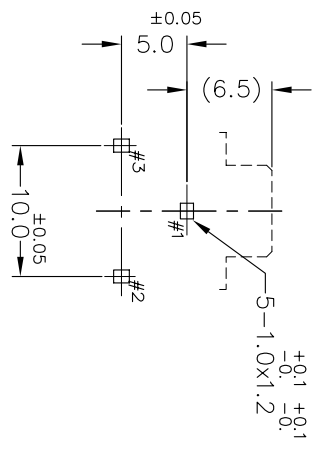
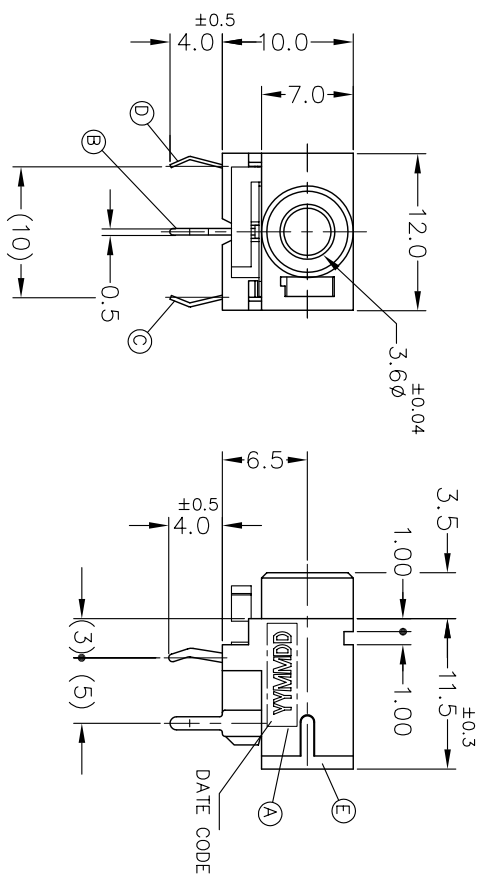
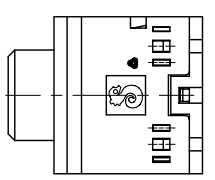

F	GROUNDING SPRING	1	STAINLESS STEEL 0.2t	N/A
E	COVER	1	PBT UL 94V-0	BLACK
D	RING SPRING	1	COPPER ALLOY 0.25t	20u"Ag PLATING ▲
C	TIP SPRING	1	COPPER ALLOY 0.3t	20u"Ag PLATING ▲
B	EARTH TERMINAL	1	BRASS 0.5t	20u"Ag PLATING ▲
A	BODY	1	PBT UL 94V-0	BLACK
NO	DESCRIPTION	QTY	MATERIAL	PLATING & COLOR
UNLESS OTHERWISE SPECIFIED TOLERANCES				
Singatron Enterprise Co., Ltd. 信音企業股份有限公司				
TITLE: Ø3.5 PHONE JACK				
DWG: 17/07/13		PART NO. 2SJ-P523-A01		
CHKD: 17/07/13		SCALE: 2/1 UNIT: mm		
APVD: 17/07/13		SIZE: A3 SHEET: 1 OF 1 REV: A		
CUSTOMER COPY				

