

REV.	ECN NO OR DESCRIPTION	REVISED	DATE
A	PDR NO:T090909-2A/2B/2C	Bruce	2009.10.17
B	ECN NO: S120324	Angus	2012.05.31
C	ECN NO: S140837	ANDY	2014.10.24
D	ECN NO: S150134	ANDY	2015.01.20

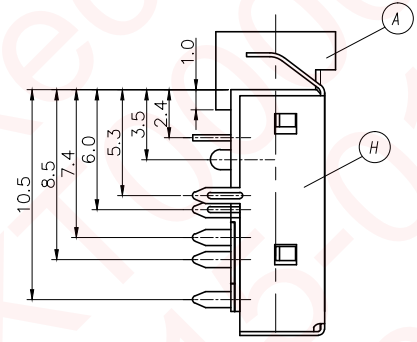

- SPECIFICATIONS:**
- INSULATION RESISTANCE BETWEEN ANY ADJACENT OPEN CIRCUIT TERMINAL SHELL NOT BE LESS THAN 100MΩ MEASURED BY 500 VDC MEGGER.
 - CONTACT RESISTANCE: 30mΩ MAX.
 - INSULATION VOLTAGE WITHSTAND: 500V AC FOR ONE MINUTE.
 - UNLESS OTHERWISE SPECIFIED, TEST IS TO BE MADE AT 5-35°C IN TEMPERATURE AND 45-85% IN HUMIDITY. BUT, IF ANY VAGUE DATA IS OCCURED ON TEST RESULT, ANOTHER TEST SHALL BE MADE AT 20°C±2°C IN TEMP., 60-70% IN HUMIDITY.
 - LIFE TEST: 5,000 CYCLES MIN. (NON-LOAD)
 - INSERTION FORCE :0.4 - 3Kg.
 - WITHDRAWAL FORCE: 0.3 - 2Kg.
 - AFTER LIFE TEST, CONTACT RESISTANCE: 50mΩ MAX.
 - AFTER HUMIDITY TEST, INSULATION RESISTANCE: 50MΩ MIN.
 - MARKING: MARK "S" ON TOP OF CONNECTOR.
 - PACKAGING : TAPE & REEL.
 - TO CONFORM TO SINGATRON HAZARDOUS SUBSTANCE FREE SPEC
 - HALOGEN FREE PRODUCT IDENTIFICATION MARK ON PRODUCT:
 - HALOGEN FREE PRODUCT IDENTIFICATION LOGO ON PACKING:
 - FOR LEAD-FREE PROCESS.

RECOMMENDED PCB LAYOUT (TOP VIEW)
(TOLERANCE: ±0.05)

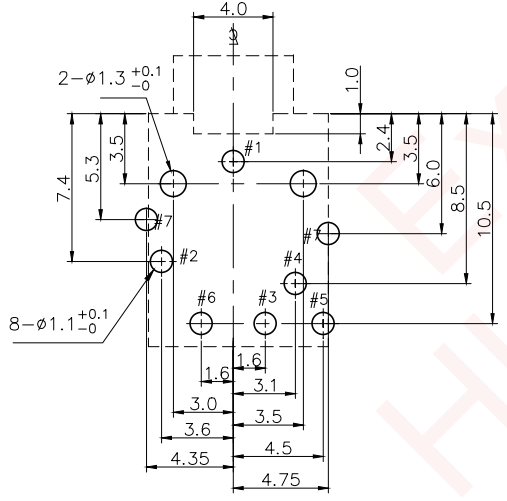
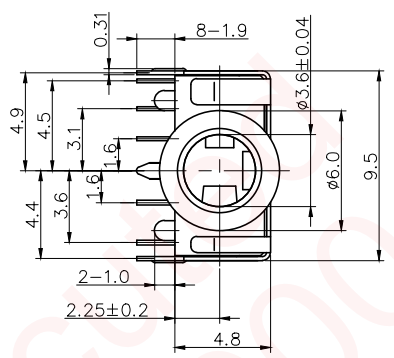
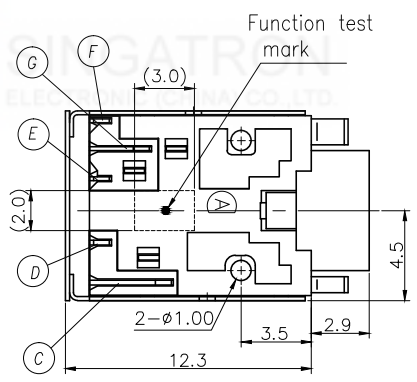
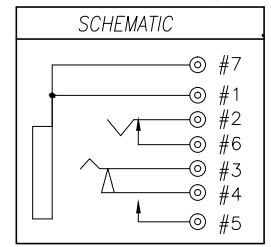
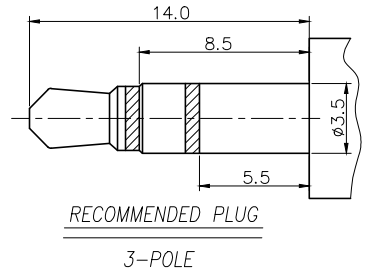

"TABLE 1"

P/N	COLOR
2SJ-S351-053	PINK (PAN#701C)
2SJ-S351-054	LIME (PAN.#577C)
2SJ-S351-055	BLUE (PAN.#284C)

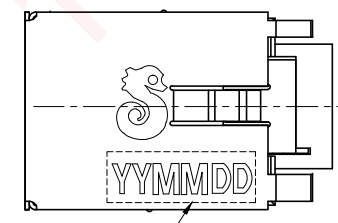

DATE CODE.

H	SHIELDING	1	PHOSPHOR BRONZE 0.2t	Ni 1.5 m MIN.
G	TRANSFER TERMINAL	1	PHOSPHOR BRONZE 0.2t	120u" Sn ON SOLDER GOLD FLASH ON CONTACT AREA OVER 50u" Ni.
F	BREAK TERMINAL	1	PHOSPHOR BRONZE 0.2t	
E	RING SPRING	1	PHOSPHOR BRONZE 0.2t	
D	SHUNT TERMINAL-A	1	BRASS 0.25t	GOLD FLASH ON CONTACT AREA OVER 50u" Ni.
C	TIP SPRING	1	PHOSPHOR BRONZE 0.25t	Ag0.5 m Min, OVER 50u" Ni.
B	EARTH	1	COPPER ALLOY 0.3t	
A	BODY	1	HIGH TEMP.THERMOPLASTIC UL 94V-0	SEE "TABLE 1"
NO	DESCRIPTION	QTY	MATERIAL	PLATING & COLOR
UNLESS OTHERWISE SPECIFIED TOLERANCES			Singatron Enterprise Co., Ltd. 信音企業股份有限公司	
DECIMALS:		TITLE		
X	:±0.5	3.5ø PHONE JACK		
X.X	:±0.3	DWN ANDY PART NO. 2SJ-S351-05X		
X.XX	:±0.2	CHKD CERRY	SCALE:4:1	UNIT: mm
		APVD LIAO	SIZE: A3	SHEET: 1 OF 1 REV: D
CUSTOMER COPY				