

REV.	ECN NO OR DESCRIPTION	REVISED	DATE
C	PDR NO.T090729-1A/B	LILI	2009.08.19
D	ECN NO.S091108	Swina	2009.11.19
E	ECN NO.S100837	Swina	2010.08.27
F	ECN NO.S100726 續修變更, 料號拆分	Cerry	2011.01.05

SPECIFICATIONS:

- INSULATION RESISTANCE BETWEEN ANY ADJACENT OPEN CIRCUIT TERMINAL SHELL NOT BE LESS THAN 100MΩ MEASURED BY 500 VDC MEGGER.
- CONTACT RESISTANCE: 30mΩ MAX.
- INSULATION VOLTAGE WITHSTAND: 500V AC FOR ONE MINUTE.
- UNLESS OTHERWISE SPECIFIED. TEST IS TO BE MADE AT 5-35°C IN TEMPERATURE AND 45-85% IN HUMIDITY. BUT, IF ANY VAGUE DATA IS OCCURED ON TEST RESULT, ANOTHER TEST SHALL BE MADE AT 20°C±2°C IN TEMP., 60-70% IN HUMIDITY.
- LIFE TEST: 5,000 CYCLES MIN. (NON-LOAD)
- INSERTION FORCE: 0.4 - 3Kg.
- WITHDRAWAL FORCE: 0.3 - 2Kg.
- AFTER LIFE TEST, CONTACT RESISTANCE: 50mΩ MAX.
- AFTER HUMIDITY TEST, INSULATION RESISTANCE: 50MΩ MIN.
- METAL, EARTH AND SHIELDING MUST BE CONDUCT.
- MARKING: MARK "S" ON TOP OF CONNECTOR.
- PACKAGING: TAPE & REEL.
- TO CONFORM TO SINGATRON HAZARDOUS SUBSTANCE FREE SPEC.
- GREEN PRODUCT IDENTIFICATION MARK ON JACK:
- GREEN PRODUCT IDENTIFICATION LABEL ON PACKAGING: **G.P. PASS**
- FOR LEAD-FREE PROCESS.

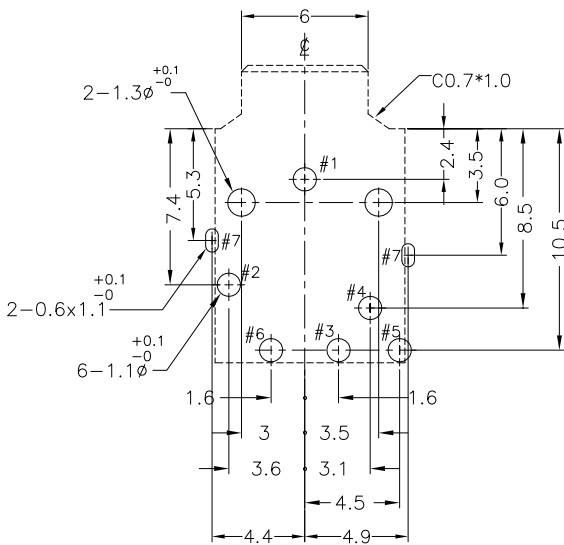
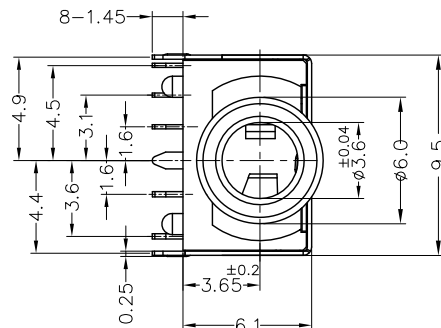
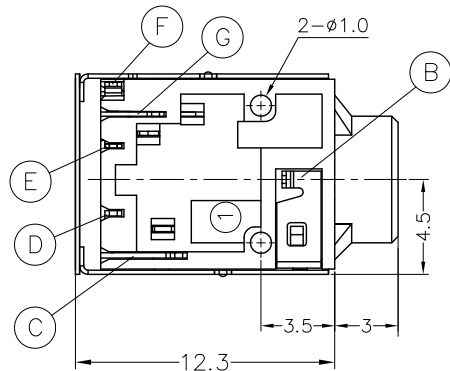

RECOMMEND PCB LAYOUT TOP VIEW(TOL.±0.05)

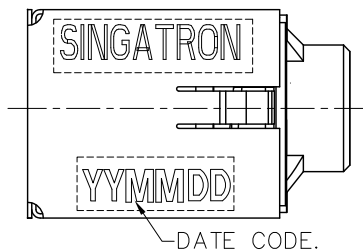
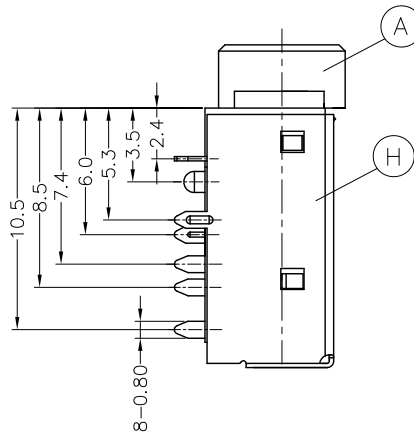
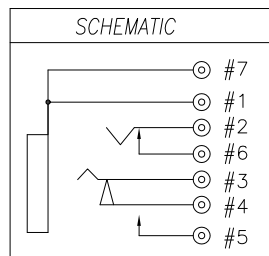
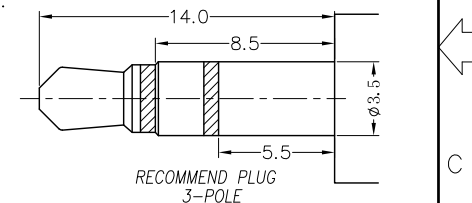

TABLE	
2SJ-S351-049	PINK(701C)
2SJ-S351-050	LIME(577C)



NO	DESCRIPTION	QTY	MATERIAL	PLATING & COLOR
H	SHIELDING	1	PHOSPHOR BRONZE 0.2t	Ni 60u"
G	TRANSFER TERMINAL	1	PHOSPHOR BRONZE 0.2t	120u" Sn ON SOLDER
F	BREAK TERMINAL	1	PHOSPHOR BRONZE 0.2t	GOLD FLASH ON CONTACT AREA ALL OVER 50u" Ni.
E	RING SPRING	1	PHOSPHOR BRONZE 0.2t	GOLD FLASH ON CONTACT AREA ALL OVER 50u" Ni.
D	SHUNT TERMINAL-A	1	BRASS 0.25t	GOLD FLASH ON CONTACT AREA ALL OVER 50u" Ni.
C	TIP SPRING	1	PHOSPHOR BRONZE 0.25t	Ag20u"Min OVER Ni20u"Min.
B	EARTH	1	PHOSPHOR BRONZE 0.2t	
A	BODY	1	HIGH TEMP.THERMOPLASTIC UL 94V-0	SEE TABLE

UNLESS OTHERWISE SPECIFIED TOLERANCES

DECIMALS: ANGLES:
 X :±0.5 X :±2°
 X.X :±0.3 X.X :±1°
 X.XX :±0.2

Singatron Enterprise Co., Ltd.
 信音企業股份有限公司

TITLE	3.5ø PHONE JACK		
DWN	Cerry	PART NO.2SJ-S351-0	□□
CHKD	Lussen	SCALE:4:1	UNIT: mm
APVD	Tony	SIZE: A3	SHEET:1 OF 1

CUSTOMER COPY