

REV.	ECN NO OR DESCRIPTION	REVISED	DATE
B	總經銷商表長度	BERYL	11/25-'02
C	ECN NO. T060321	JACKY	2006.11.21

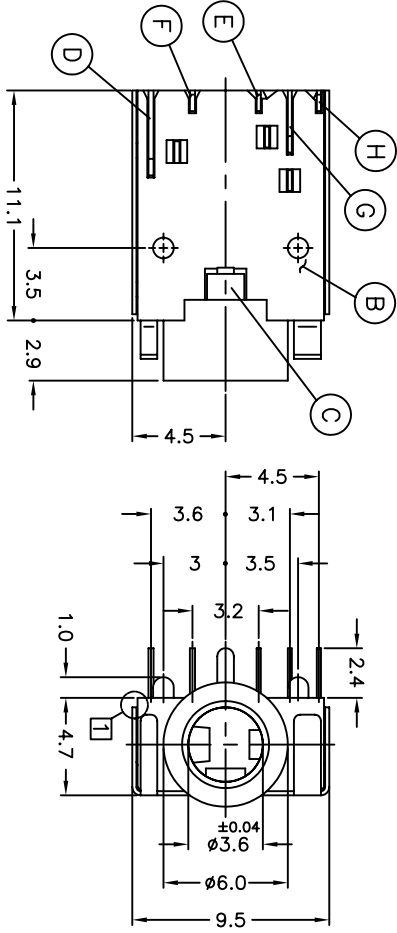

- SPECIFICATIONS:
- INSULATION RESISTANCE BETWEEN ANY ADJACENT OPEN CIRCUIT TERMINAL SHELL NOT BE LESS THAN 100M Ω MEASURED BY 500 VDC MEGGER.
 - CONTACT RESISTANCE: 50m Ω MAX.
 - DIELECTRIC VOLTAGE WITHSTAND: 500V AC FOR ONE MINUTE.
 - UNLESS OTHERWISE SPECIFIED, TEST IS TO BE MADE AT 5-35°C IN TEMPERATURE AND 45-85% IN HUMIDITY. BUT IF ANY VAGUE DATA IS OCCURED ON TEST RESULT, ANOTHER TEST SHALL BE MADE AT 20°C±2°C IN TEMP., 60-70% IN HUMIDITY.
 - LIFE TEST: 5,000 CYCLES MIN. (NON-LOAD)
 - INSERTION FORCE: 0.4 - 3Kg.
 - WITHDRAWAL FORCE: 0.3 - 2Kg.
 - AFTER LIFE TEST, CONTACT RESISTANCE: 50m Ω MAX.
 - AFTER HUMIDITY TEST, INSULATION RESISTANCE: 50M Ω MIN.
 - MARKING: MARK "S" ON TOP OF CONNECTOR.
 - PACKING: TAPE & REEL.
 - GREEN PRODUCT IDENTIFICATION MARK IN JACK:
 - GREEN PRODUCT IDENTIFICATION LABEL IN PACKING:
 - FOR LEAD-FREE PROCESS.
 - PRINTED DATE CODE "YMMDD" ON TOP OF CONNECTOR.

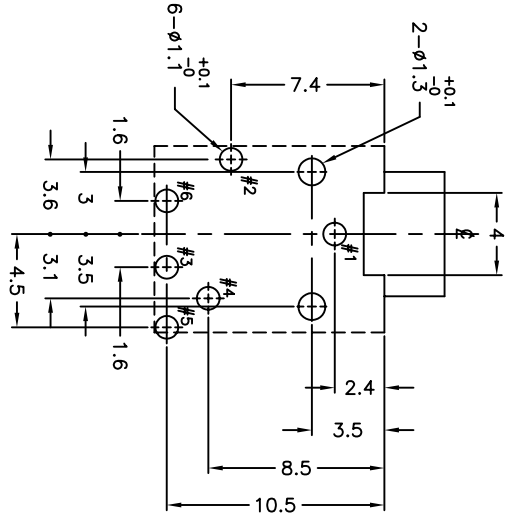
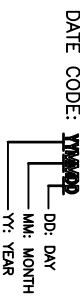
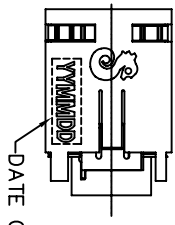

RECOMMENDED PCB LAYOUT
TOP VIEW (TOLERANCE: ±0.05)

Circuit:

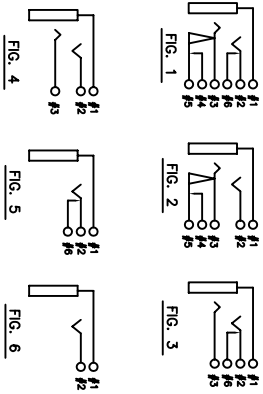

DRAWING NO.	CIRCUIT	RING SPRING	SHUNT TERMINAL A	BREAK TERMINAL	TRANSFER TERMINAL
ZSJ-S920-021	FIG. 1	1	1	1	1
ZSJ-S921-021	FIG. 2	1			1
ZSJ-S922-021	FIG. 3	1	1		
ZSJ-S923-021	FIG. 4	1			
ZSJ-S924-021	FIG. 5				1
ZSJ-S925-021	FIG. 6				

NO	DESCRIPTION	QTY	MATERIAL	PLATING & COLOR
I	SHIELDING	1	PHOSPHOR BRONZE 0.2t	NICKEL PLATING
H	TRANSFER TERMINAL	*	PHOSPHOR BRONZE 0.2t	SILVER PLATING
G	BREAK TERMINAL	*	BRASS 0.2t	SILVER PLATING
F	SHUNT TERMINAL-A	*	BRASS 0.25t	SILVER PLATING
E	RING SPRING	*	PHOSPHOR BRONZE 0.2t	SILVER PLATING
D	TIP SPRING	1	PHOSPHOR BRONZE 0.25t	SILVER PLATING
C	EARTH	1	COPPER ALLOY 0.3t	SILVER PLATING
B	SEPARATOR	1	HIGH TEMP THERMOPLASTIC UL 94V-0	BLACK COLOR
A	BODY	1	HIGH TEMP THERMOPLASTIC UL 94V-0	PINK COLOR (PANTONE NO.701C)

UNLESS OTHERWISE SPECIFIED TOLERANCES

DECIMALS:	ANGLES:
X : ±0.5	X : ±2°
X.X : ±0.3	X.X : ±1'
X.XX : ±0.2	

TITLE: 3.5Φ PHONE JACK

DWN: JAN 2006.11.21 PRT NO. 2SJ-S920-021
CHKD: LHO 2006.11.21 SCALE: 4/1 UNIT: mm
APVD: ANEZA 2006.11.21 SIZE: A3 SHEET: 1 OF 1 REV: C

Singatron Enterprise Co., Ltd.
信營企業股份有限公司

CUSTOMER COPY