

REV.	ECN NO. OR DESCRIPTION	REVISED	DATE
A	PDR NO.: T091126-2A	Bobbie	2010.01.05

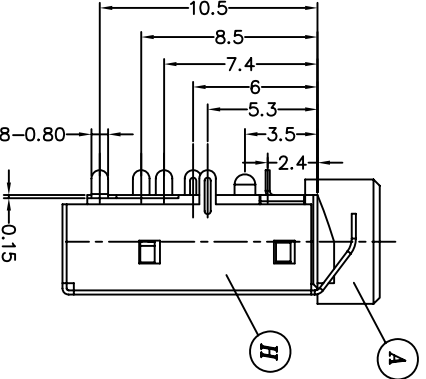

RECOMMENDED PCB LAYOUT (TOP VIEW)  
(TOLERANCE: ±0.05)

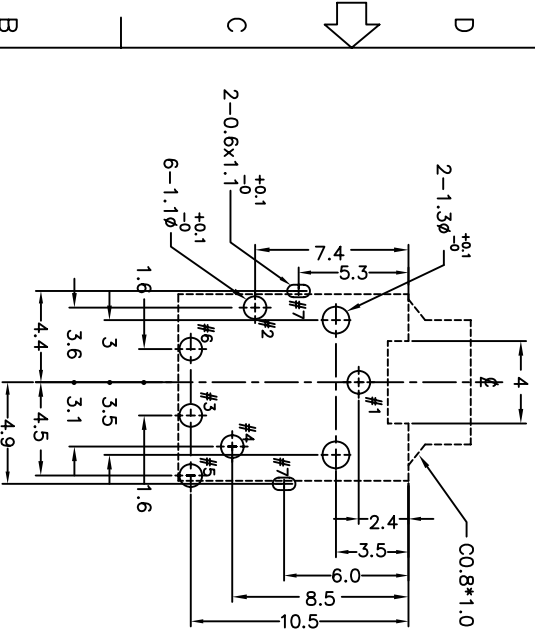
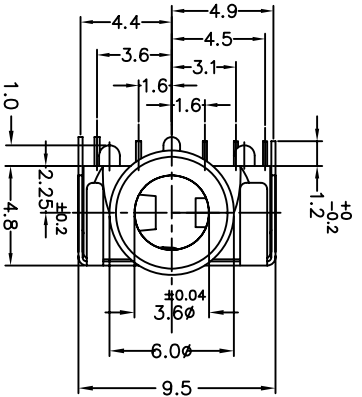
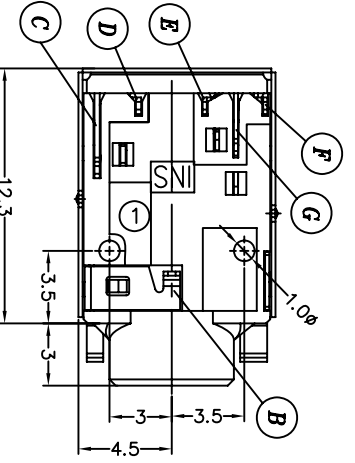
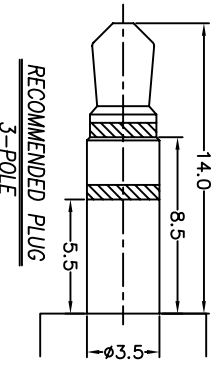

SCHEMATIC

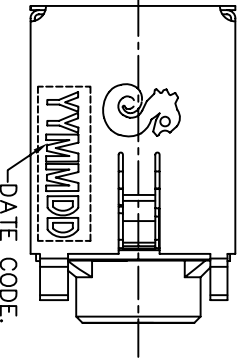
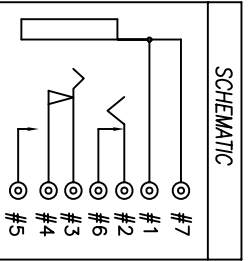

- SPECIFICATIONS:
- INSULATION RESISTANCE BETWEEN ANY ADJACENT OPEN CIRCUIT TERMINAL SHELL NOT BE LESS THAN 100M Ω MEASURED BY 500 VDC MEGGER.
  - CONTACT RESISTANCE: 30mΩ MAX. (200mΩ MAX: METAL TO EARTH TO SHIELDING)
  - INSULATION VOLTAGE WITHSTAND: 500V AC FOR ONE MINUTE.
  - UNLESS OTHERWISE SPECIFIED. TEST IS TO BE MADE AT 5-35°C IN TEMPERATURE AND 45-85% IN HUMIDITY. BUT, IF ANY VAGUE DATA IS OCCURED ON TEST RESULT, ANOTHER TEST SHALL BE MADE AT 20°C ± 2°C IN TEMP., 60-70% IN HUMIDITY.
  - LIFE TEST: 5,000 CYCLES MIN. (NON-LOAD)
  - INSERTION FORCE: 0.4 - 3kg.
  - WITHDRAWAL FORCE: 0.3 - 2kg.
  - AFTER LIFE TEST, CONTACT RESISTANCE: 50mΩ MAX.
  - AFTER HUMIDITY TEST, INSULATION RESISTANCE: 50M Ω MIN.
  - MARKING: MARK "S" ON TOP OF CONNECTOR.
  - PACKAGING: TAPE & REEL.
  - TO CONFORM TO SINGATRON HAZARDOUS SUBSTANCE FREE SPEC.
  - HALOGEN FREE PRODUCT IDENTIFICATION MARK ON PRODUCT:
  - HALOGEN FREE PRODUCT IDENTIFICATION LOGO ON PACKAGING:
  - FOR LEAD-FREE PROCESS.



H	SHIELDING	1	PHOSPHOR BRONZE 0.2t	NI 60U" MIN.
G	TRANSFER TERMINAL	1	PHOSPHOR BRONZE 0.2t	120U" Sn ON SOLDER TAIL
F	BREAK TERMINAL	1	PHOSPHOR BRONZE 0.2t	GOLD FLASH ON CONTACT AREA ALL OVER 50U" IN.
E	RING SPRING	1	PHOSPHOR BRONZE 0.2t	
D	SHUNT TERMINAL-A	1	BRASS 0.25t	GOLD FLASH ON CONTACT AREA ALL OVER 50U" IN.
C	TIP SPRING	1	PHOSPHOR BRONZE 0.25t	
B	EARTH	1	COPPER ALLOY 0.2t	Ag20U Min. ALL OVER 50U" IN.
A	BODY	1	HIGH TEMP THERMOPLASTIC UL 94V-0	BLACK COLOR
	DESCRIPTION	QTY	MATERIAL	PLATING & COLOR
	UNLESS OTHERWISE SPECIFIED TOLERANCES			
	DECIMALS:	ANGLES:		
	±0.5	X ± 12°		
	±0.3	X.X ± 1°		
	±0.2			
	X.XXX ± 0.1			
TITLE		3.5Φ PHONE JACK		
DWN	Bobbie	PART NO.	2SJ-7351-028	
CHKD	Boye	SCALE: 4/1	UNIT:	mm
APVD	MAX	SIZE: A3	SHEET: 1 OF 1	REV: A

Singatron Enterprise Co., Ltd.  
信譽企業股份有限公司

CUSTOMER COPY