

\*: INDICATES THE KEY DIMENSIONS [\*為重點尺寸]

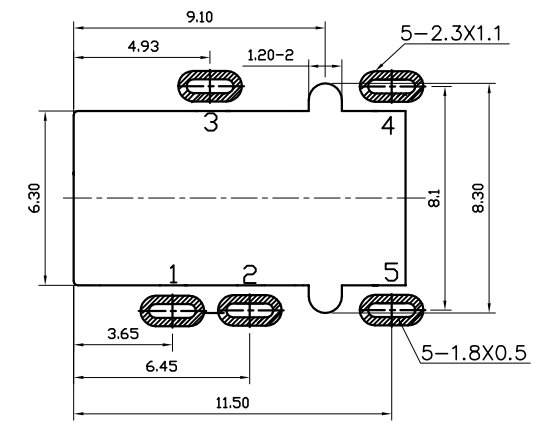

Recommend of PC Board Holes  
Tolerance :  $\pm 0.05$ (Top view)

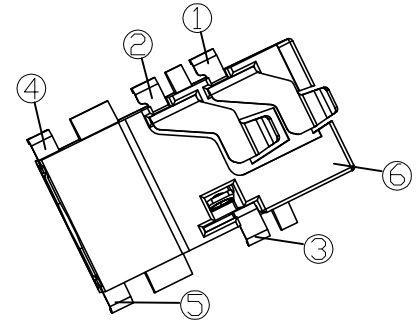
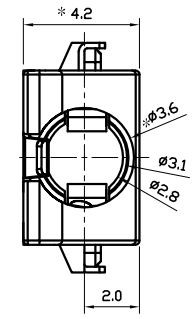
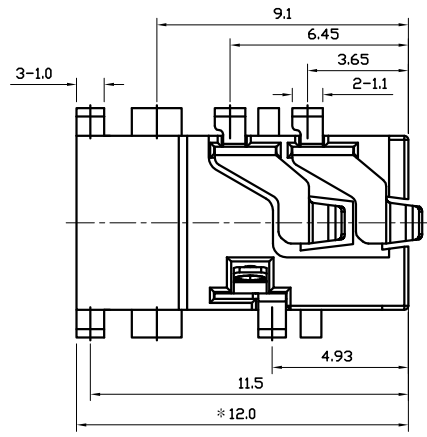
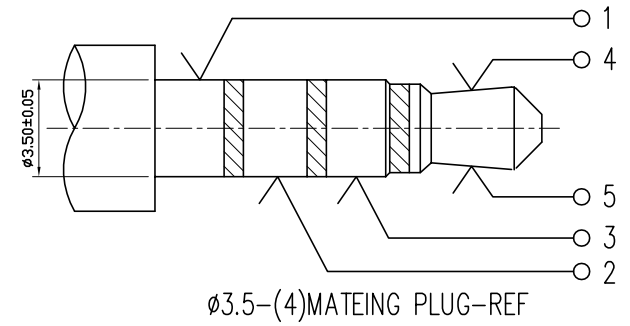
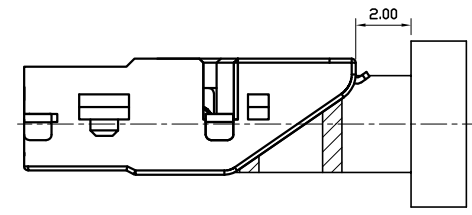
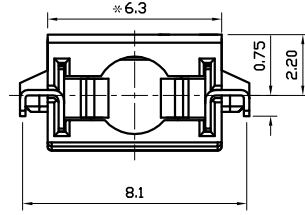
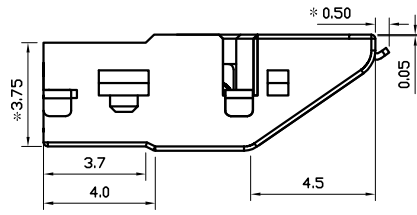

- Notes:
- Electrical Characteristics:
    - Rating : DC 30V 0.5 A ;
    - Contact Resistance: 50m $\Omega$  Max.(Initial), 100m $\Omega$  Max.(Final) After test:  $\leq 50$ m $\Omega$  ;
    - Dielectric Withstanding Voltage: 500V AC for One Minute ;
    - Insulation Resistance: 100M $\Omega$  Min. Measured By 500 VDC;
  - Mechanical Characteristics:
    - Plug Insertion Force 0.3~3.0Kgf (initial), 0.3~3.0Kgf (Final) life test;
    - Plug Extraction Force: 0.3~3.0Kgf (initial), 0.3~3.0Kgf (Final) life test;
  - Durability Test: 5,000 Cycles min;
  - Operating temperature:-25 $^{\circ}$ C ~ +70 $^{\circ}$ C;
  - Soldering Heat Resistance Reflow Soldering 260 $^{\circ}$ C;
  - Plug Interface Dimensions Conform To EIAJ RC-5325A Spec;
  - Packaging:Tape Reel ;

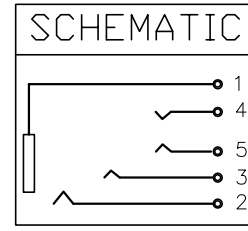

6	HOUSING	1	PPA	UL94V-0	BLACK
5	TERMINAL 5#	1	PHOSPHOR BRONZE	MB: Ni	Gold Flash
4	TERMINAL 4#	1	PHOSPHOR BRONZE	MB: Ni	Gold Flash
3	TERMINAL 3#	1	PHOSPHOR BRONZE	MB: Ni	Gold Flash
2	TERMINAL 2#	1	PHOSPHOR BRONZE	MB: Ni	Gold Flash
1	TERMINAL 1#	1	PHOSPHOR BRONZE	MB: Ni	Gold Flash
LTR	PART NAME	QTY	MATERIAL	REMARK	

-TOLERANCES- UNLESS OTHERWISE SPECIFIED 公差		Singatron Enterprise Co., Ltd.			
		TITLE MINIATURE JACK			
X.X $\pm 0.30$	X.X" $\pm 3$ "	DWN	LUJIAO 2019.08.22	PART NO. 2SJ-W035-147JSAF	
X.XX $\pm 0.20$	X.XX" $\pm 1$ "	CHKD	GAOWEI 2019.08.22	SCALE 1:1	UNIT: mm
X.XXX $\pm 0.15$		APVD	GAOWEI 2019.08.22	SIZE: A3	SHEET:1 OF 1
CUSTOMER COPY					
REV: A					

HALOGEN FREE