

*: INDICATES THE KEY DIMENSIONS 【*为重點尺寸】

| * REVISIONS | | | | |
|-------------|-------------|------|---------|----------|
| LTR | DESCRIPTION | DATE | REVISED | APPROVED |

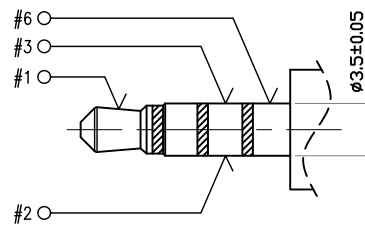

φ3.5-(4)POLE PLUG

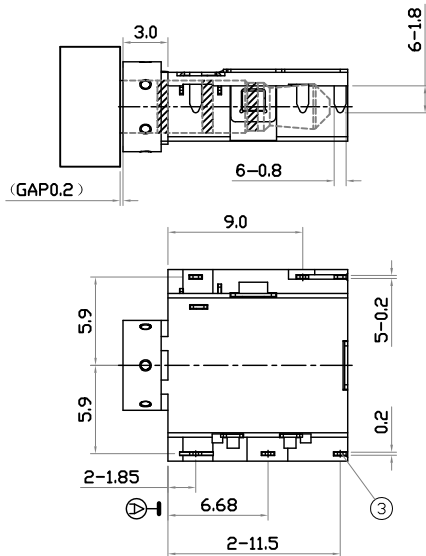
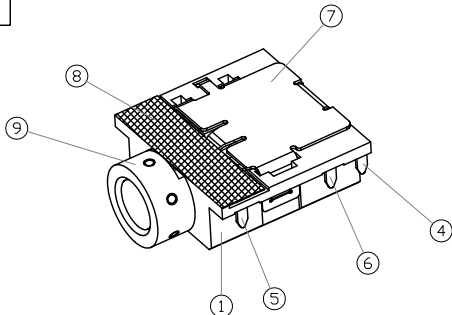
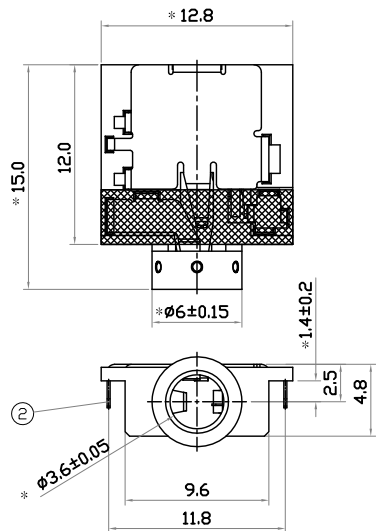
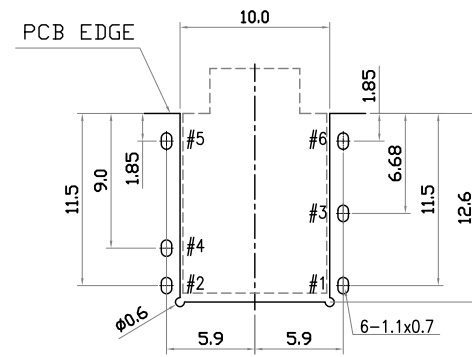
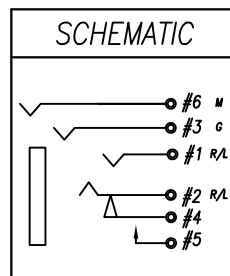

Recommend of PC Board Holes
Tolerance : ±0.05(Printed-Top view)

Notes:

- Electrical Characteristics:
 - Rating : DC 30V 0.5 A ;
 - Contact Resistance: 30mΩ Max.(Initial),
Between plug and contact 100mΩ Max;
(Final) After Life test: ≤60mΩ ;
 - Dielectric Withstanding Voltage: 500V AC for One Minute ;
 - Insulation Resistance: 100MΩ Min. Measured By 500 VDC;
- Mechanical Characteristics:
 - Plug Insertion Force 0.3~3.0Kgf (initial),
0.3~3.0Kgf (Final) life test;
 - Plug Extraction Force: 0.3~3.0Kgf (initial),
0.3~3.0Kgf (Final) life test;
- Durability Test: 5,000 Cycles min;
- Operating temperature:-25°C ~ +70°C;
- Soldering Heat Resistance Reflow Soldering 260°C;
- Plug Interface Dimensions Conform To EIAJ RC-5325A Spec;
- Packaging: ;

LEAD FREE

| 9 | LOOP | 1 | BRASS | MB:Ni | GOLD FLASH |
|-----|-------------------|-----|--------------|---------|------------|
| 8 | MYLAR | 1 | | | |
| 7 | SHIELD | 1 | METAL | Ni | PLATED |
| 6 | TRANSFER TERMINAL | 1 | COPPER ALLOY | MB:Ni | GOLD FLASH |
| 5 | MAKE TERMINAL | 1 | COPPER ALLOY | MB:Ni | GOLD FLASH |
| 4 | RING SPRING | 1 | COPPER ALLOY | MB:Ni | GOLD FLASH |
| 3 | TIP SPRING | 1 | COPPER ALLOY | MB:Ni | GOLD FLASH |
| 2 | EARTH SPRING | 1 | COPPER ALLOY | MB:Ni | GOLD FLASH |
| 1 | HOUSING | 1 | PA9T | UL-94V0 | BLACK |
| LTR | PART NAME | QTY | MATERIAL | REMARK | |

| -TOLERANCES- UNLESS OTHERWISE SPECIFIED 公差 | |
|--|-----------|
| X.X ±0.30 | X.X' ±3° |
| X.XX ±0.25 | X.XX' ±1° |
| X.XXX ±0.20 | |

| Singatron Enterprise Co., Ltd. | | | |
|--------------------------------|-------------------|-----------------------|------------------------|
| TITLE | MINIATURF JACK | | |
| DWN | RP 2014.06.25 | PART NO. 2SJ-W035-148 | |
| CHKD | GAOWEI 2014.06.24 | SCALE 1:1 | UNIT: mm |
| APVD | GAOWEI 2014.06.24 | SIZE: A3 | SHEET: 1 OF 1 REV: 001 |
| CUSTOMER COPY | | | |