

\*: INDICATES THE KEY DIMENSIONS [“\*”為重點尺寸]

* REVISIONS				
LTR	DESCRIPTION	DATE	REVISED	APPROVED

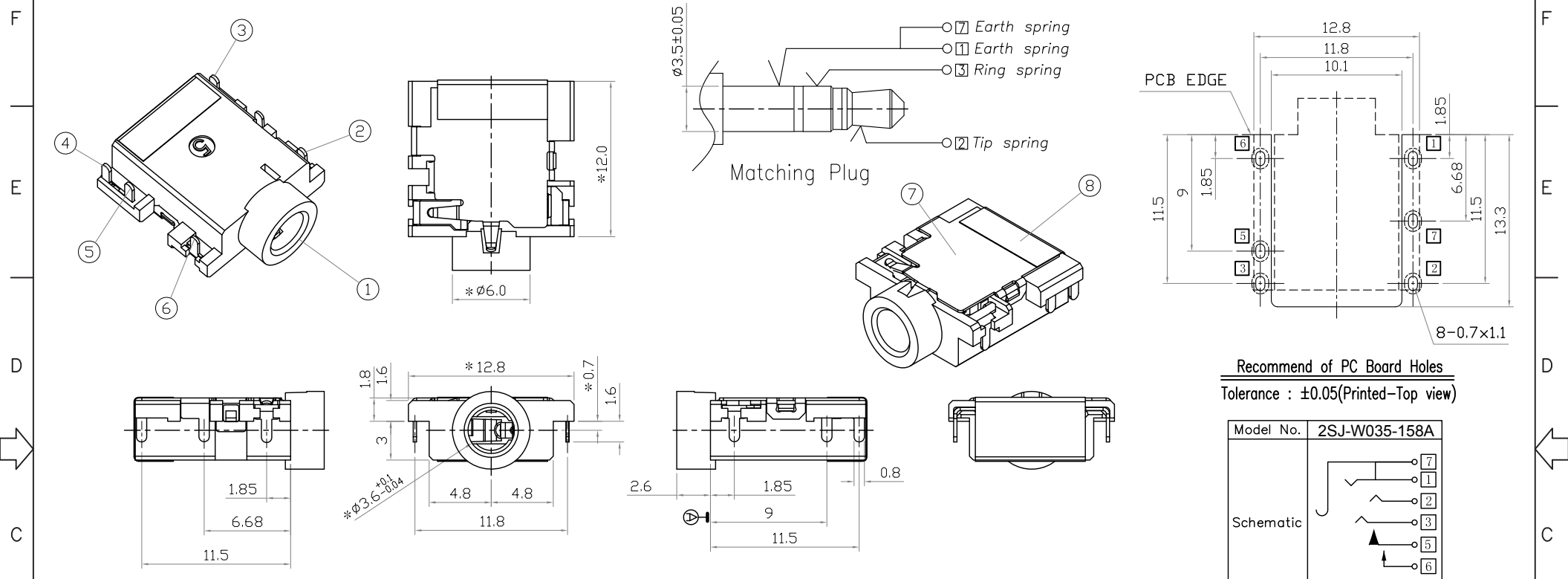

Recommend of PC Board Holes  
Tolerance : ±0.05(Printed-Top view)

Model No.	2SJ-W035-158A
Schematic	

- Notes:
- Electrical Characteristics:
    - Rating : DC 30V 0.5 A ;
    - Contact Resistance: 50mΩ Max.(Initial), 100mΩ Max.(Final) After test: ≤50mΩ ;
    - Dielectric Withstanding Voltage: 500V AC for One Minute ;
    - Insulation Resistance: 100MΩ Min. Measured By 500 VDC;
  - Mechanical Characteristics:
    - Plug Insertion Force 0.3~3.0Kgf (initial), 0.3~3.0Kgf (Final) life test;
    - Plug Extraction Force: 0.3~3.0Kgf (initial), 0.3~3.0Kgf (Final) life test;
  - Durability Test: 5,000 Cycles min;
  - Operating temperature:-25°C ~ +70°C;
  - Soldering Heat Resistance Reflow Soldering 260°C;
  - Plug Interface Dimensions Conform To EIAJ RC-5325A Spec;
  - Packaging:Tape Reel;

8	MYLAR	1			
7	MAKE SPRING	1	Copper alloy	MB:Ni	Ni PLATED
6	MAKE SPRING	1	Copper alloy	MB:Ni	Ag PLATED
5	TRANSFER SPRING	1	Copper alloy	MB:Ni	Ag PLATED
4	RING SPRING	1	Copper alloy	MB:Ni	Ag PLATED
3	TIP SPRING	1	Copper alloy	MB:Ni	Ag PLATED
2	EARTH SPRING-A	1	Copper alloy	MB:Ni	Ag PLATED
1	HOUSING	1	PA9T	UL94V-0	BLACK
LTR	PART NAME	QTY	MATERIAL	REMARK	

-TOLERANCES- UNLESS OTHERWISE SPECIFIED 公差		Singatron Enterprise Co., Ltd.			
		TITLE MINIATURF JACK			
		DWN H.RP2014.09.19 PART NO. 2SJ-W035-158A			
		CHKD SAOWE2014.09.19 SCALE 1:1 UNIT: mm			
		APVD SAOWF2014.09.19 SIZE: A3 SHEET:1 OF 1 REV: 001			
CUSTOMER COPY					

RoHS Compliant