

REV	EQN NO	OR DESCRIPTION	REVISED	DATE
B	EQR NO.1090020	AMY	2009.05.06	
C	增加限位防止鐵殼鬆脫 EQN C100172	ARES	2010.05.24	
D	EQN NO:C100404 Add Dimension	LONGJIANG	2010.12.27	

**SPECIFICATIONS:**

1. ELECTRICAL CHARACTERISTICS:
- 1-1. RATING: 12V 1A
  - 1-2. CONTACT RESISTANCE: 30mΩ MAX (INITIAL)
  - 1-3. DIELECTRIC WITHSTANDING VOLTAGE: 500V AC FOR ONE MINUTE.
  - 1-4. INSULATION RESISTANCE: 100MΩMIN. MEASURED BY 500 VDC
2. MECHANICAL CHARACTERISTICS:
- 2-1. INSERTION FORCE : 0.3~3.0 KGF
  - 2-2. WITHDRAWAL FORCE : 0.3~3.0 KGF
3. LIFE TEST: 5,000 CYCLES MIN.
4. OTHER GENERAL SPEC. TO REFER "2SJ1019 SERIES SPEC".
5. TO CONFORM TO SINGATRON HAZARDOUS SUBSTANCE FREE SPEC.
6. HALOGEN FREE PRODUCT IDENTIFICATION MARK ON JACK:
7. HALOGEN FREE PRODUCT IDENTIFICATION LABEL ON PACKAGING:
8. FOR REFLOW SOLDERING LEAD-FREE PROCESS.

SCALE 10:1  
DATE CODE

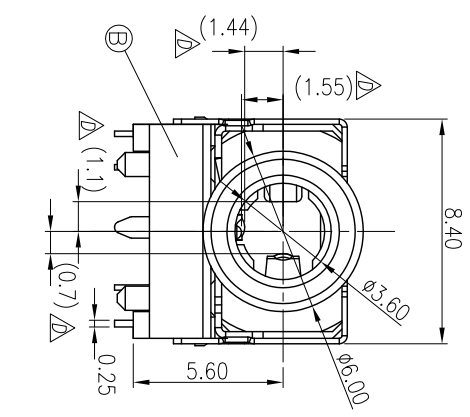
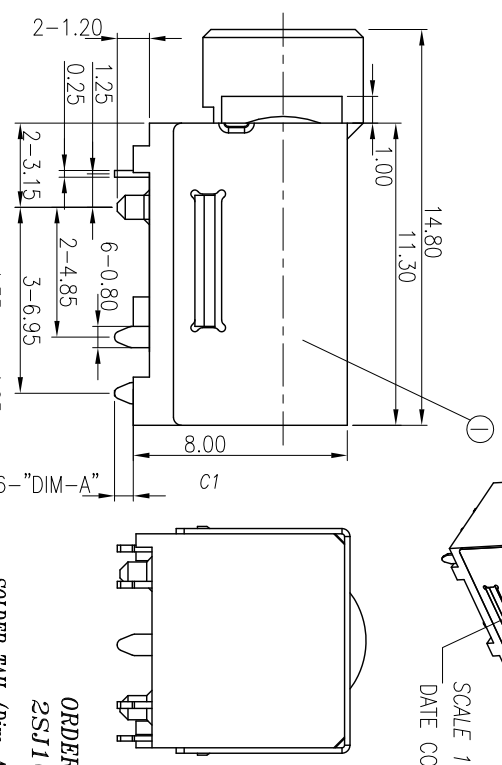
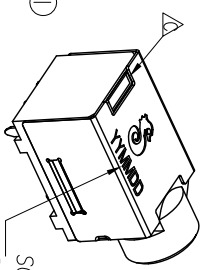

**ORDERING NO.**  
**2SJ1019-0X1XX1**

**SOLDER TAIL (Dim-A)**  
0: 0.7±0.1/-0.2mm (PCB T=0.8mm)  
1: 1.2±0.1/-0.2mm (PCB T=1.4mm)

**SLEEVE TYPE**  
1. Without metal

**PACKAGING**  
1.TAPE & REEL

**BODY/COVER COLOR**  
1.Black

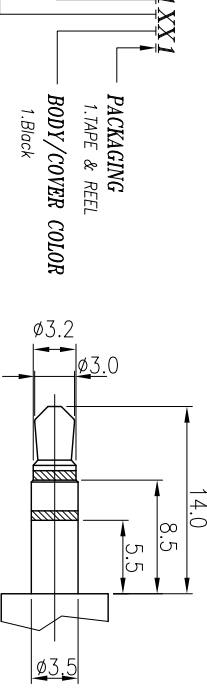

RECOMMENDED PLUG  
SCALE 2.5:1 TOL.±0.05mm

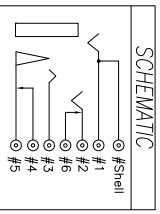
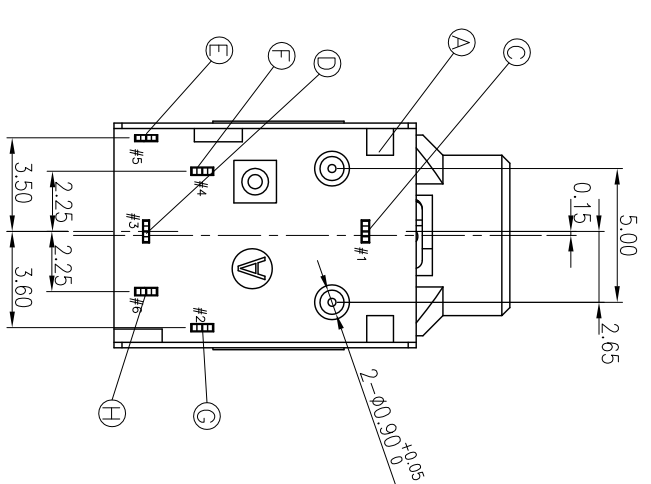
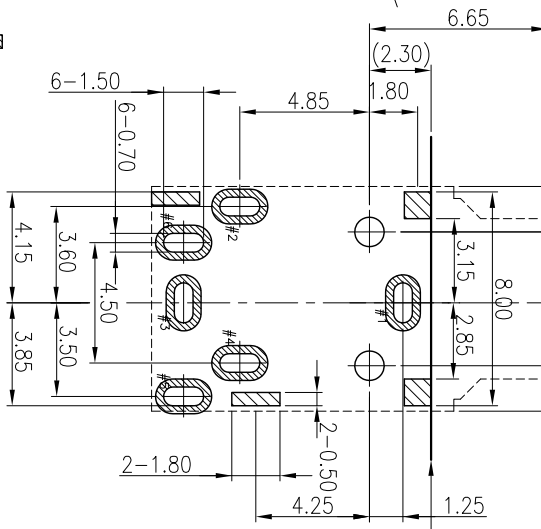

stand-off area  
Recommended PCB Layou  
<TOP VIEW> TOLERANCE ±0.05

ITEM	DESCRIPTION	QTY	MATERIAL	PLATING & COLOR
I	SHELL	1	STAINLESS STEEL	N/A
H	SHUNT TERMINAL	1	COPPER ALLOY 0.25T	SEE ORDERING NO. SPEC
G	TIP SPRING	1	COPPER ALLOY 0.25T	SEE ORDERING NO. SPEC
F	B-TERMINAL	1	COPPER ALLOY 0.25T	SEE ORDERING NO. SPEC
E	T-TERMINAL	1	COPPER ALLOY 0.2T	SEE ORDERING NO. SPEC
D	RING SPRING	1	COPPER ALLOY 0.2T	SEE ORDERING NO. SPEC
C	EARTH	1	COPPER ALLOY 0.25T	SEE ORDERING NO. SPEC
B	COVER	1	HIGHT TEMP. THERMOPLASTIC	SEE ORDERING NO. SPEC
A	BODY	1	HIGHT TEMP. THERMOPLASTIC	SEE ORDERING NO. SPEC
NO	DESCRIPTION	QTY	MATERIAL	PLATING & COLOR

UNLESS OTHERWISE SPECIFIED TOLERANCES

Singatron Enterprise Co., Ltd.

DECIMALS:	ANGLES:
X : ±0.5	X : ±2°
X.X : ±0.3	X.X : ±1'
X.XX : ±0.2	

TITLE	3.5φ AUDIO JACK
DWN	Longjiang 11010103
CHKD	zzz 11010103
APVD	11010103
PART NO.	2SJ1019-0X1XX1
SCALE	5:1
UNIT:	mm
SIZE:	A3
SHEET:	1 OF 1
REV:	D

CUSTOMER COPY

