

REV. ECN NO OR DESCRIPTION	REVISED	DATE
A PRODUCT RELEASE	ARSS	2012.03.14

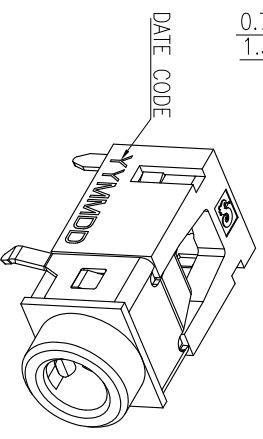
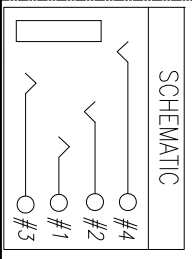
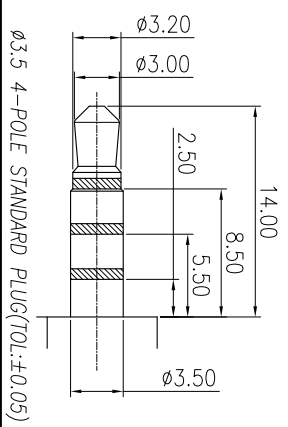
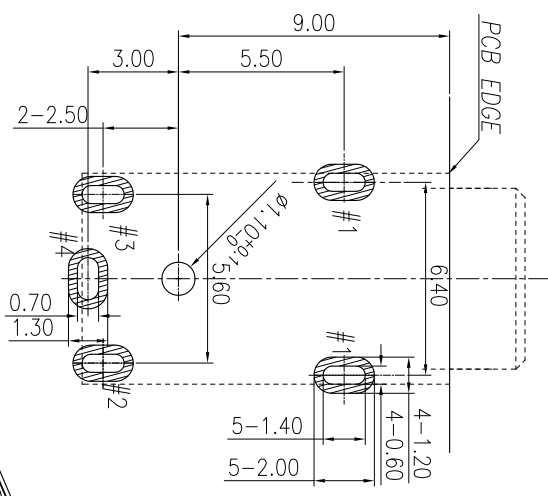
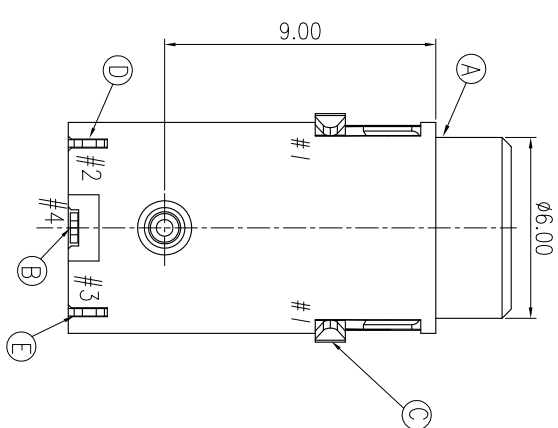
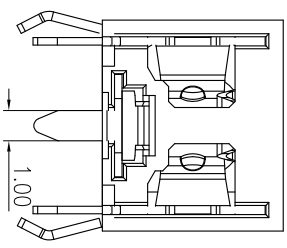
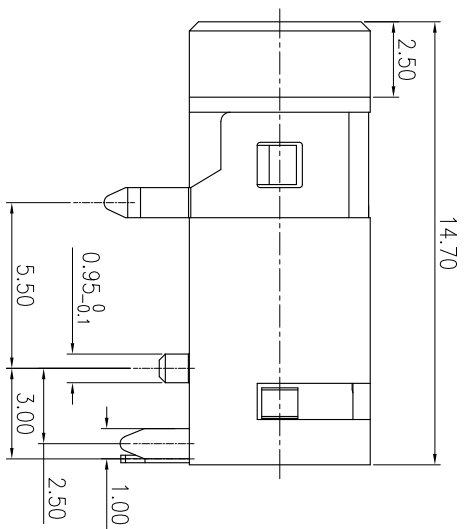
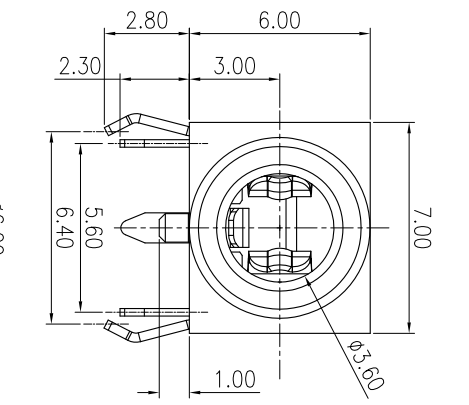

- SPECIFICATIONS:
1. ELECTRICAL CHARACTERISTICS:
- 1-1. RATING: 12V 1A
 - 1-2. CONTACT RESISTANCE: 30m Ω MAX (INITIAL)
 - 1-3. DIELECTRIC WITHSTANDING VOLTAGE: 500V AC FOR ONE MINUTE.
 - 1-4. INSULATION RESISTANCE: 100M Ω MIN. MEASURED BY 500 VDC
2. MECHANICAL CHARACTERISTICS:
- 2-1. INSERTION FORCE : 0.3~3.0 kgf .
 - 2-2. WITHDRAWAL FORCE : 0.3~3.0 kgf .
- 3. LIFE TEST: 5,000 CYCLES .
 - 4. OTHER GENERAL SPEC. TO REFER "GENERAL SPEC".
 - 5. TO CONFORM TO SINGATRON HAZARDOUS SUBSTANCE FREE SPEC.
 - 6. GREEN PRODUCT IDENTIFICATION MARK ON JACK:
 - 7. GREEN PRODUCT IDENTIFICATION LABEL ON PACKAGING: **G.P. PASS**
 - 8. FOR WAVE SOLDERING LEAD-FREE PROCESS.
 - 9. PACKAGING: TRAY.

E	RING SPRING B	1	COPPER ALLOY 0.25T	GOLD FLASH
D	RING SPRING A	1	COPPER ALLOY 0.25T	GOLD FLASH
C	TIP SPRING	1	COPPER ALLOY 0.30T	GOLD FLASH
B	EARTH SPRING	1	COPPER ALLOY 0.25T	GOLD FLASH
A	BODY	1	PBT 94V-0	Yellow 012C
NO	DESCRIPTION	QTY	MATERIAL	PLATING & COLOR

UNLESS OTHERWISE SPECIFIED TOLERANCES

Singatron Enterprise Co., Ltd.
信亨企業股份有限公司

TITLE	Ø3.5 PHONE JACK		
DWN	Rev: 2012.03.13	PART NO. 2S11520-004111H	
CHKD	Wshon 2012.03.13	SCALE 5:1	UNIT: mm
APVD	Liao 2012.03.13	SIZE: A3	SHEET: 10F1
			REV: A

DECIMALS: ANGLES:

X : ±0.5 X : ±2°

X.X : ±0.3 X.X : ±1°

X.XX : ±0.2

CUSTOMER COPY