

Product application:  
The spring working position when Plug-In.

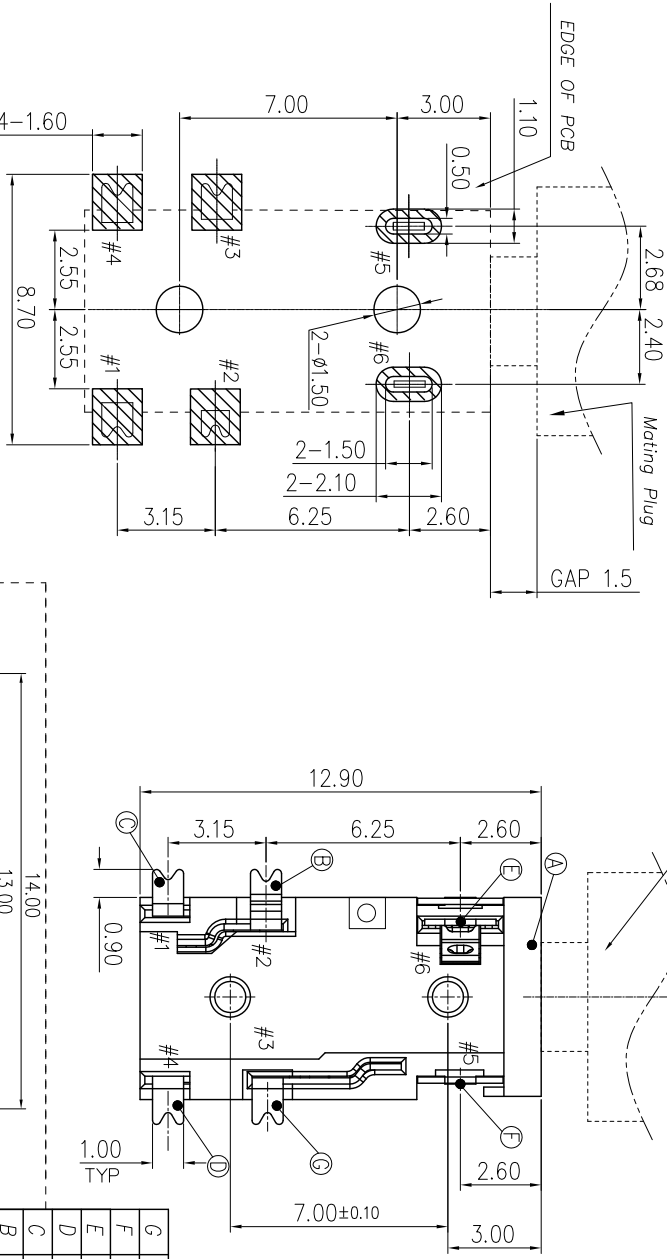

RECOMMENDED PCB LAYOUT  
TOP VIEW (TOLERANCE: ±0.05)

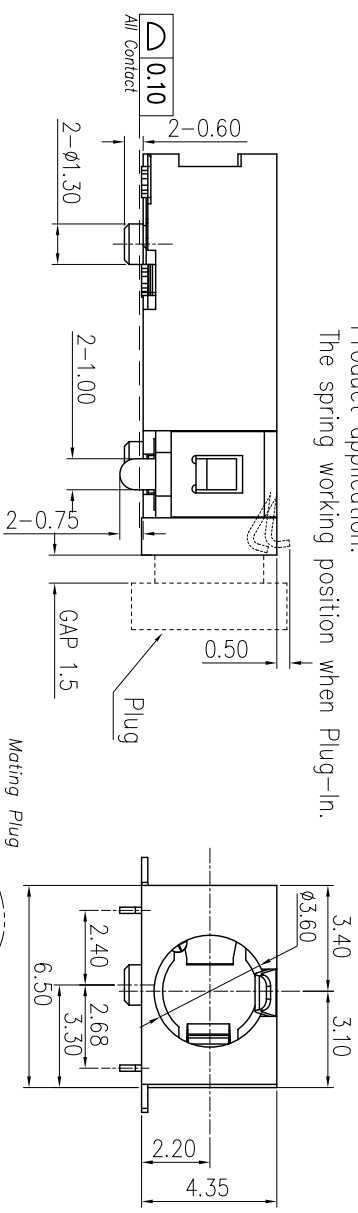
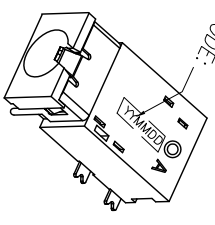
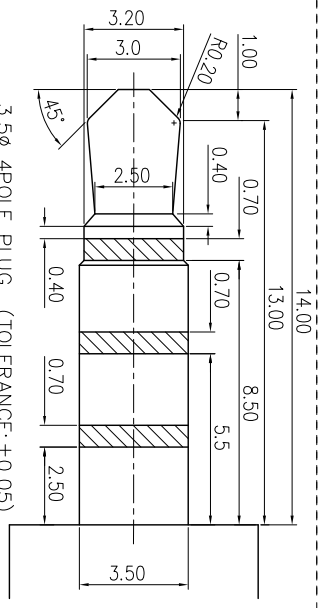
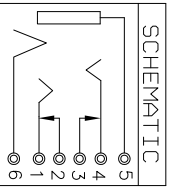

- SPECIFICATIONS:**
- 1. ELECTRICAL CHARACTERISTICS:
    - 1-1. RATING : 12V /1A
    - 1-2. CONTACT RESISTANCE: 30mΩ MAX(INITIAL).
    - 1-3. DIELECTRIC WITHSTANDING VOLTAGE 500V AC FOR ONE MINUTE
    - 1-4. INSULATION RESISTANCE :100mΩ MIN. MEASURED BY 500VDC
  - 2. MECHANICAL CHARACTERISTICS:
    - 2-1. INSERTION FORCE : 0.3~3.0 KGf
    - 2-2. WITHDRAWAL FORCE : 0.3~3.0 KGf
  - 3. LIFE TEST: 5,000 CYCLES.
  - 4. TO CONFORM TO THE SINGATON HSF SPECIFICATION.
  - 5. HALOGEN FREE PRODUCT IDENTIFICATION MARK ON PRODUCT.
  - 6. HALOGEN PRODUCT IDENTIFICATION LABEL ON PACKAGING.
  - 7. FOR REFLOW SOLDERING LEAD-FREE PROCESS.
  - 8. SOLDER HEAT RESISTANCE REFLOW SOLDERING 260°C 10SECS.
  - 9. PACKAGING: TAPE & REEL.

G	SHUNT-B	1	COPPER ALLOY 0.2t	Gold Flush
F	EARTH SPRING	1	COPPER ALLOY 0.2t	3.0 MIN Pd/Ni on contact area oil over Ni Plated.
E	RING SPRING-B	1	COPPER ALLOY 0.2t	
D	RING SPRING-A	1	COPPER ALLOY 0.2t	Gold flush on contact area And solder telli oil over
C	TIP SPRING	1	COPPER ALLOY 0.2t	Nickel plated
B	SHUNT-A	1	COPPER ALLOY 0.2t	Gold Flush
A	BODY	1	HIGH TEMP.THERMOPLASTIC	BLACK
NO	DESCRIPTION	QTY	MATERIAL	PLATING & COLOR
UNLESS OTHERWISE SPECIFIED TOLERANCES				
Singatton Enterprise Co., Ltd. 信音企業股份有限公司				
TITLE		3.5Ø PHONE JACK		
DWM	ZLS	20121208	PART NO. 2SJ2269-003131F	
CHKD	ZLD	20121213	SCALE 4:1	UNIT: mm
APVD	UMQ	20121213	SIZE: A3	SHEET: 10F1
CUSTOMER COPY				

REV.	ECN NO OR DESCRIPTION	REVISED	DATE
A	PRODUCT RELEASE	ZLS	2012.12.05