

REV.	ECN NO OR DESCRIPTION	REVISED	DATE
A	PRODUCT RELEASE	LANDY	2013.07.04

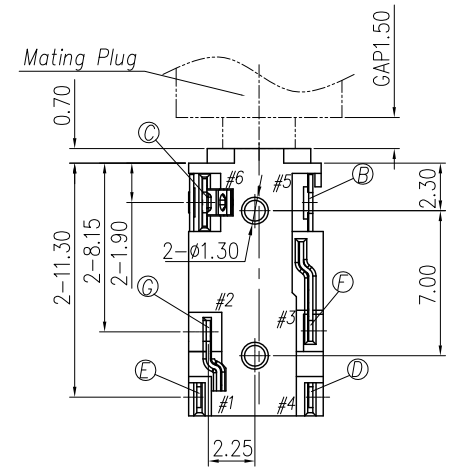
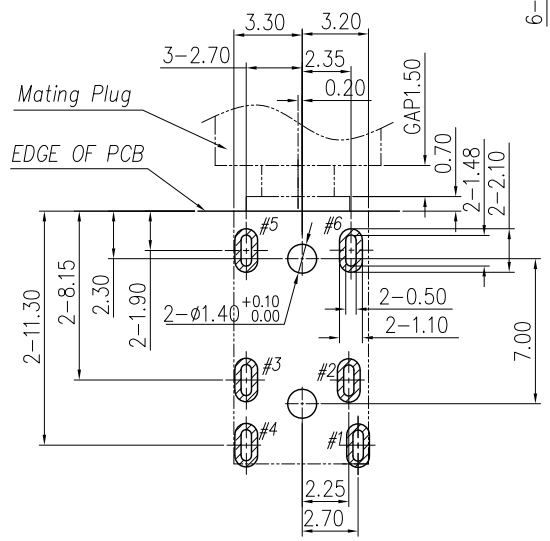
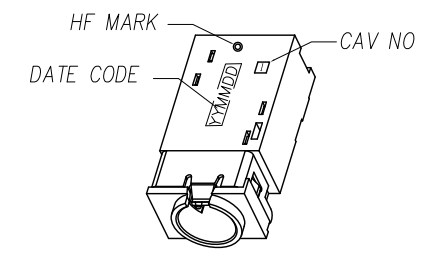
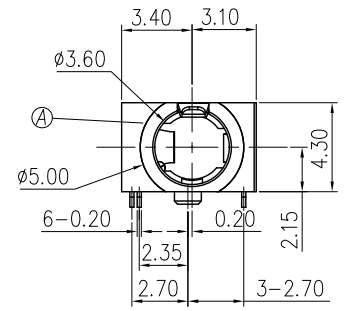
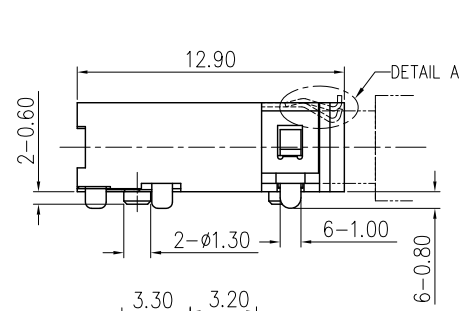

SPECIFICATIONS:

- ELECTRICAL CHARACTERISTICS:
 - RATING: 12V/1A
 - CONTACT RESISTANCE: 30mΩ MAX.
 - DIELECTRIC WITHSTANDING VOLTAGE: 500V AC FOR ONE MINUTE.
 - INSULATION RESISTANCE: 100MΩ MIN. MEASURED BY 500 VDC
- MECHANICAL CHARACTERISTICS:
 - INSERTION FORCE : 0.3~3.0 KGF
 - WITHDRAWAL FORCE : 0.3~3.0 KGF
- LIFE TEST: 5000 CYCLES MIN.
- OTHER GENERAL SPEC. TO REFER "3.5ø PHONE JACK SPEC".
- TO CONFORM TO THE SINGATRON HAZARDOUS SUBSTANCE FREE SPEC.
- HALOGEN FREE PRODUCT IDENTIFICATION MARK ON JACK: Ⓞ
- HALOGEN FREE PRODUCT IDENTIFICATION LABEL ON PACKAGING:
- FOR REFLOW SOLDERING LEAD-FREE PROCESS.
- PACKAGING: TAPE&REEL

RECOMMENDED PCB LAYOUT T=1.20
TOP VIEW (TOLERANCE: ±0.05)

G	SHUNT-A	1	COPPER ALLOY 0.2t	GOLD FLASH ON CONTACT AREA AND SOLDER TAIL, ALL OVER NICKEL PLATED
F	SHUNT-B	1	COPPER ALLOY 0.2t	
E	TIP	1	COPPER ALLOY 0.2t	
D	RING -A	1	COPPER ALLOY 0.2t	
C	RING -B	1	COPPER ALLOY 0.2t	
B	EARTH	1	COPPER ALLOY 0.2t	
A	BODY	1	HI-TEMP THERMOPLASTIC	BLUE
NO	DESCRIPTION	QTY	MATERIAL	PLATING & COLOR

UNLESS OTHERWISE SPECIFIED TOLERANCES		Singatron Enterprise Co., Ltd. 信音企業股份有限公司	
DECIMALS:	ANGLES:	TITLE	3.5ø PHONE JACK
X : ±0.5	X : ±2°	DWN	Landy 13/7/18 PART NO. 2SJ2269-004122F
XX : ±0.3	XX : ±1°	CHKD	Winkan 13/7/18 SCALE 4:1 UNIT: mm
XXX : ±0.2		APVD	Liao 13/7/18 SIZE: A3 SHEET: 1 OF 1 REV: A
CUSTOMER COPY			

