

REV.	ECN NO OR DESCRIPTION	REVISED	DATE
A	PRODUCT RELEASE	Kermit	2014.06.03
B	ECN NO: S161108-P	YUREN	2017.7.26

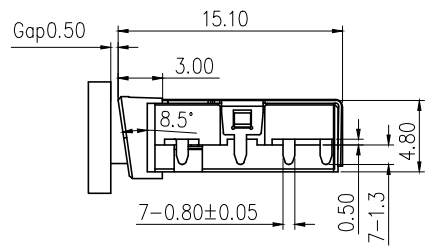

- SPECIFICATIONS:**
- ELECTRICAL CHARACTERISTICS:
    - RATING: 12V, 1A.
    - CONTACT RESISTANCE:
      - 30 MILLIOHMS Max. FOR INITIAL,
      - 50 MILLIOHMS Max. AFTER 5000 CYCLES.
    - INSULATION RESISTANCE: 100 MEGAOHMS Min. BY 500V DC AFTER 1 MINUTE.
    - DIELECTRIC WITHSTANDING VOLTAGE: 500V RMS AFTER 1 MINUTE.
  - MECHANICAL CHARACTERISTICS:
    - INSERTION FORCE : 0.4~3.0 KGF
    - WITHDRAWAL FORCE : 0.3~2.0 KGF
  - LIFE TEST: 5,000 CYCLES .
  - OTHER GENERAL SPEC. TO REFER "2SJ2285 SERIES SPEC".
  - TO CONFORM TO SINGATRON HAZARDOUS SUBSTANCE FREE SPEC.
  - HALOGEN FREE PRODUCT IDENTIFICATION MARK ON PRODUCT: Ⓞ
  - HALOGEN FREE PRODUCT IDENTIFICATION LABEL ON PACKAGING:
  - FOR REFLOW SOLDERING LEAD-FREE PROCESS.
  - PACKAGING: TAPE&REEL.

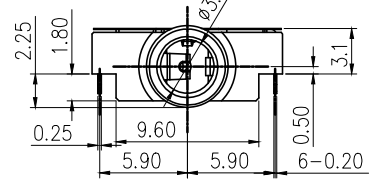
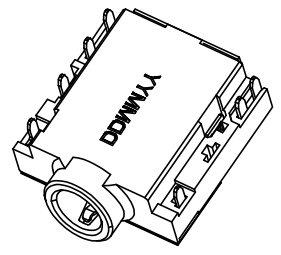
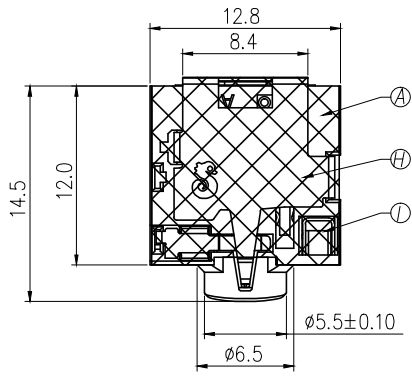
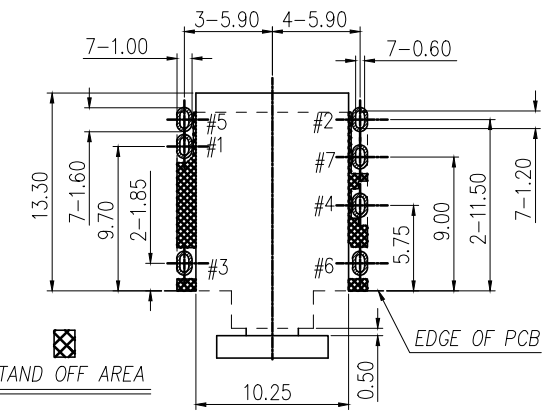
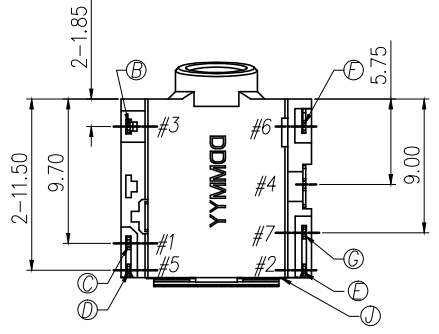

J	MYLAR	1	KAPTON T=0.075MM	YELLOW TRANSPARENT
I	MYLAR	1	KAPTON T=0.05MM	YELLOW TRANSPARENT
H	SHELL	1	PHOSPHOR BRONZE T=0.20MM	NI 60%/Min PLATED
G	TRANSFER TERMINAL	1	PHOSPHOR BRONZE T=0.20MM	GOLD FLASH ON CONTACT AREA, GOLD FLASH ON SOLDER TAIL, OVER NI 50%/Min PLATED
F	BREAK TERMINAL	1	PHOSPHOR BRONZE T=0.20MM	GOLD FLASH ON SOLDER TAIL, OVER NI 50%/Min PLATED
E	RING	1	PHOSPHOR BRONZE T=0.20MM	GOLD FLASH ON CONTACT AREA, GOLD FLASH ON SOLDER TAIL, OVER NI 50%/Min PLATED
D	SHUNT	1	BRASS T=0.20MM	GOLD FLASH ON SOLDER TAIL, OVER NI 50%/Min PLATED
C	TIP	1	PHOSPHOR BRONZE T=0.25MM	GOLD FLASH ON CONTACT AREA, GOLD FLASH ON SOLDER TAIL, OVER NI 50%/Min PLATED
B	EARTH	1	PHOSPHOR BRONZE T=0.20MM	GOLD FLASH ON CONTACT AREA, GOLD FLASH ON SOLDER TAIL, OVER NI 50%/Min PLATED
A	BODY	1	PPS+45%GF A305M45B UL94V-0	BLACK
NO	DESCRIPTION	QTY	MATERIAL	PLATING & COLOR

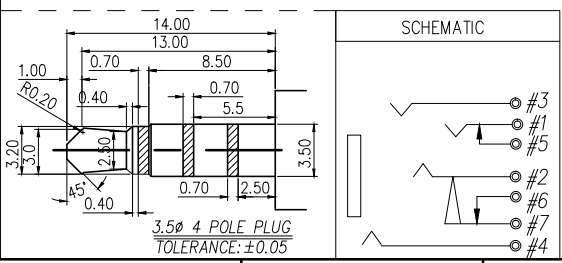

RECOMMENDED P.C.B. LAYOUT T=1.00  
TOP VIEW (TOLRANCE: ±0.05)

UNLESS OTHERWISE SPECIFIED TOLERANCES		DECIMALS:		ANGLES:		TITLE		3.5mm PHONE JACK	
X	:±0.5	X	:±2°	DWN YUREN PART NO. 2SJ2284-007592F					
X.X	:±0.3	X.X	:±1°	CHKD	CERRY	SCALE 1:1	UNIT: mm	APVD LIAO SIZE: A3 SHEET: 10F1 REV: B	
X.XX	:±0.2	CUSTOMER COPY							