

REV.	ECN NO OR DESCRIPTION	REVISED	DATE
A	PDR NO:ST10406-1A	BILLY	2011.06.25
B	ECN NO:CT10383 ADD MYLAR	BILLY	2011.12.21
C	ECN:C120005 ADD MATING DRAWING	Downen	2012.02.21

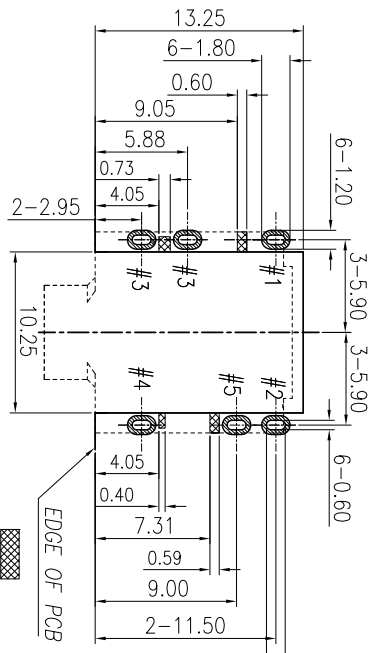

RECOMMENDED P.C.B. LAYOUT T=1.00  
TOP VIEW (TOLERANCE: ±0.05)

EDGE OF PCB  
STAND-OFF

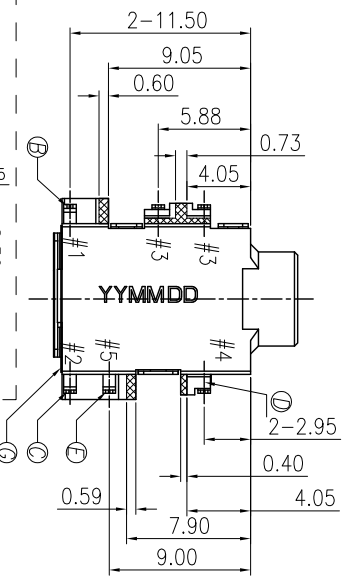
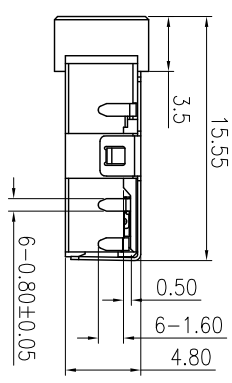
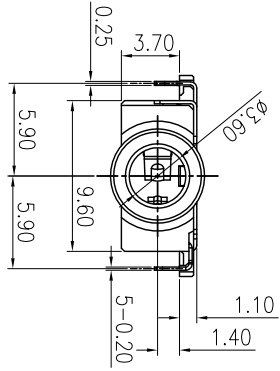
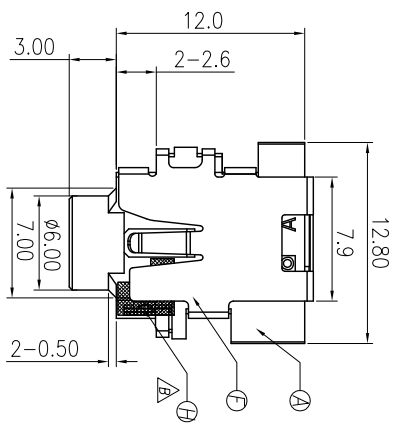
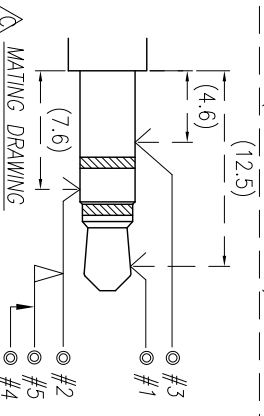
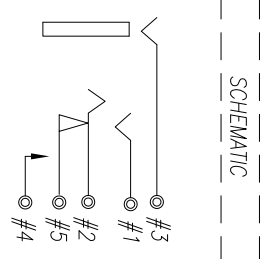
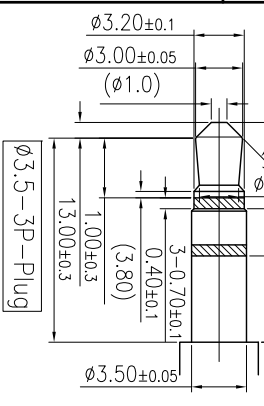

- SPECIFICATIONS:
- ELECTRICAL CHARACTERISTICS:
    - RATING: 36V AC, 1A DC.
    - CONTACT RESISTANCE: 50m Ω MAX. (INITIAL), 100m Ω MAX. (AFTER LIFE TEST)
    - DIELECTRIC WITHSTANDING VOLTAGE: 500V AC FOR ONE MINUTE.
    - INSULATION RESISTANCE (TEST VOLTAGE: 500 V DC): 100MΩ MIN. (INITIAL), 50MΩ MIN AFTER LIFE TEST.
  - MECHANICAL CHARACTERISTICS:
    - INSERTION FORCE : 0.4~3.0 KGf
    - WITHDRAWAL FORCE : 0.3~2.0 KGf
  - LIFE TEST: 5,000 CYCLES MIN.
  - OTHER GENERAL SPEC. TO REFER "2SJ2285 SERIES SPEC".
  - TO CONFORM TO THE SINGATRON HAZARDOUS SUBSTANCE FREE SPEC.
  - HALOGEN FREE PRODUCT IDENTIFICATION MARK ON JACK: Ⓢ
  - HALOGEN FREE PRODUCT IDENTIFICATION LABEL ON PACKAGING: Ⓢ
  - FOR REFLOW SOLDERING LEAD-FREE PROCESS.
  - PACKAGING: TAPE&REEL.



NO	DESCRIPTION	QTY	MATERIAL	PLATING & COLOR
A	BODY	1	HIGH TEMP.THERMOPLASTIC UL 94V-0	BLACK COLOR
B	TIP	1	COPPER ALLOY 0.25T	
C	RING	1	COPPER ALLOY 0.20T	
D	MAKE TERMINAL	1	COPPER ALLOY 0.20T	GOLD FLASH
E	TRANSFER TERMINAL	1	COPPER ALLOY 0.20T	GOLD FLASH ON CONTACT AND SOLDER BALL ALL OVER NICKEL PLATED
F	SHIELD	1	COPPER ALLOY 0.20T	NICKEL PLATED
G	MYLAR	1	MYLAR 0.075T	
H	MYLAR	1	MYLAR 0.10T	

Singatron Enterprise Co., Ltd.  
信音企業股份有限公司

PART NO. 2SJ2285-012499F

3.5ø PHONE JACK  
TITLE  
DWN  
CHKD  
APVD  
SCALE 1:1  
SIZE: A3  
SHEET: 10F1  
REV: C  
CUSTOMER COPY