

REV.	ECN NO OR DESCRIPTION	REVISED	DATE
A	PRODUCT RELEASE	REX	2015.05.13

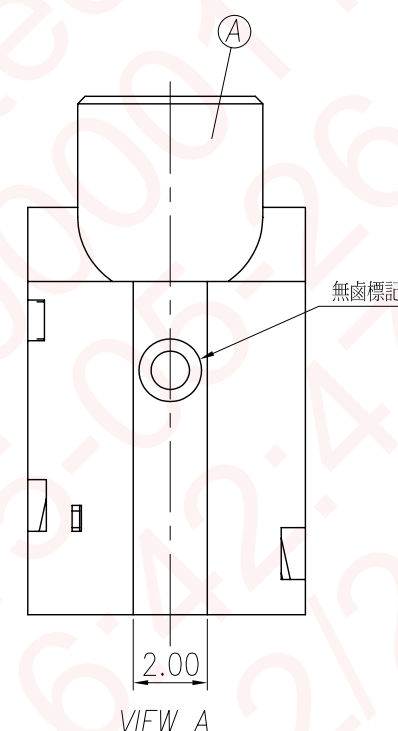

SPECIFICATIONS:

- ELECTRICAL CHARACTERISTICS:
 - 1-1. RATING: 12V/1A
 - 1-2. CONTACT RESISTANCE: 30mΩ MAX.
 - 1-3. DIELECTRIC WITHSTANDING VOLTAGE: 500V AC FOR ONE MINUTE
 - 1-4. INSULATION RESISTANCE: 100MΩ MIN. MEASURED BY 500 VDC
- MECHANICAL CHARACTERISTICS:
 - 2-1. INSERTION FORCE : 0.3~3.0 KGF (INITIAL)
 - 2-2. WITHDRAWAL FORCE : 0.3~3.0 KGF (INITIAL)
 - 2-1. INSERTION FORCE : 0.2~3.0 KGF (AFTER LIFE TEST)
 - 2-2. WITHDRAWAL FORCE : 0.2~3.0 KGF (AFTER LIFE TEST)
- LIFE TEST: 5,000 CYCLES MIN.
- OTHER GENERAL SPEC. TO REFER "2SJ2287 SERIES SPEC".
- TO CONFORM TO THE SINGATRON HARDUABRON SUBSTANCE FREE SPEC.
- GREEN PRODUCT IDENTIFICATION MARK ON JACK: ⊙
- GREEN PRODUCT IDENTIFICATION LABEL ON PACKAGING:

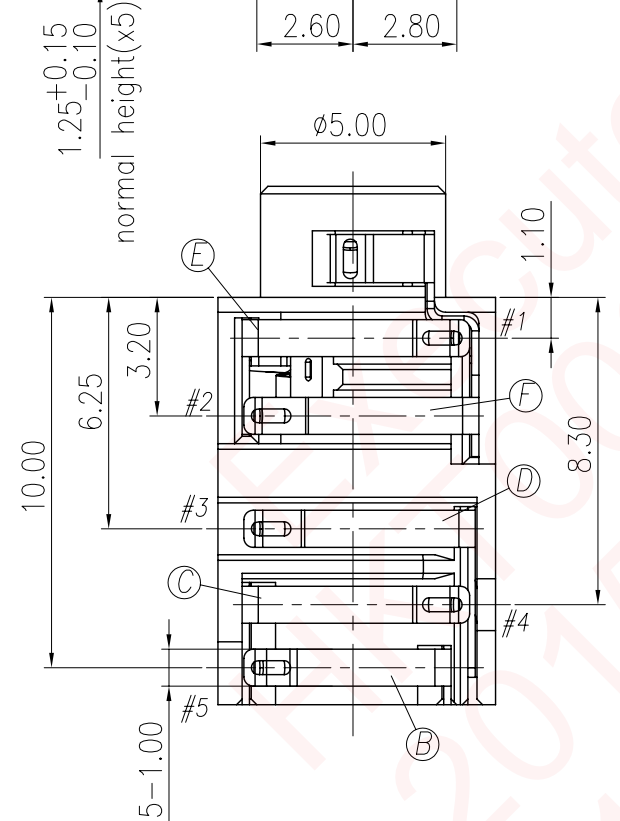
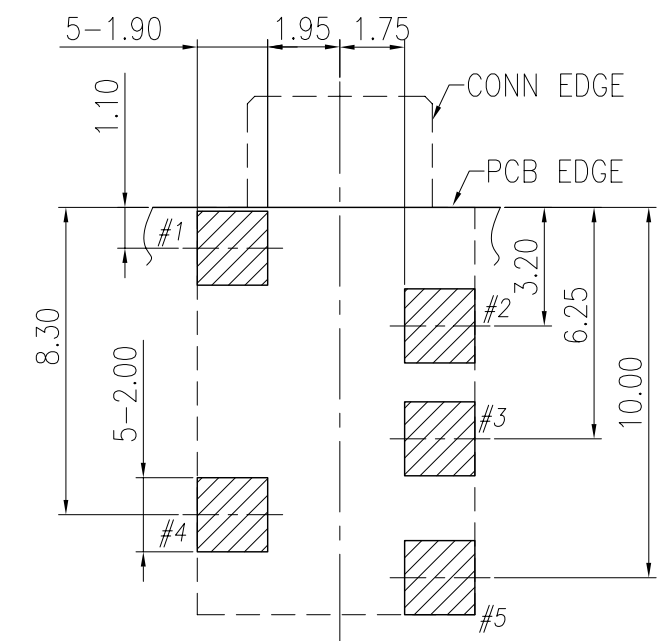
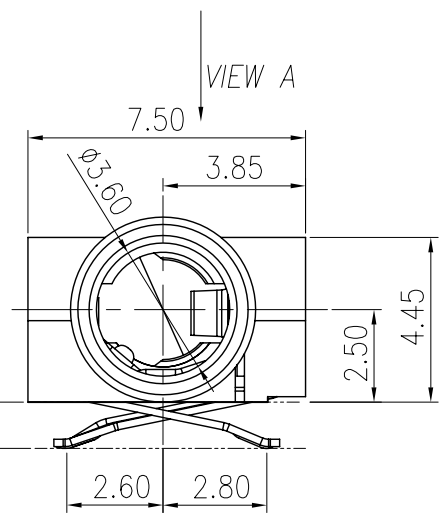
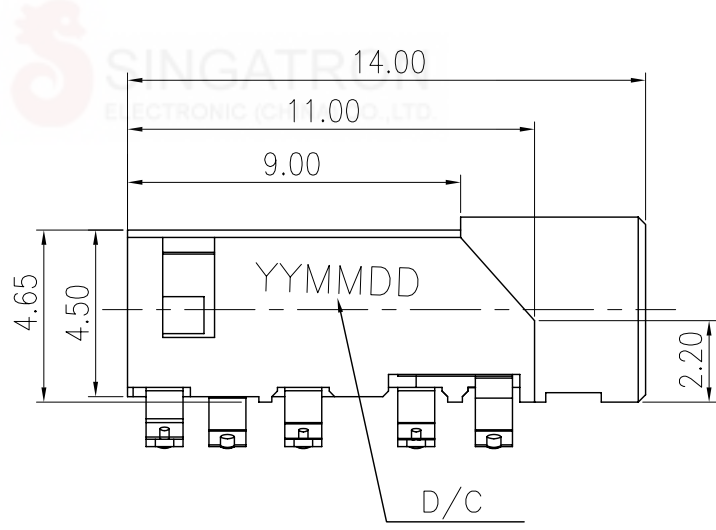
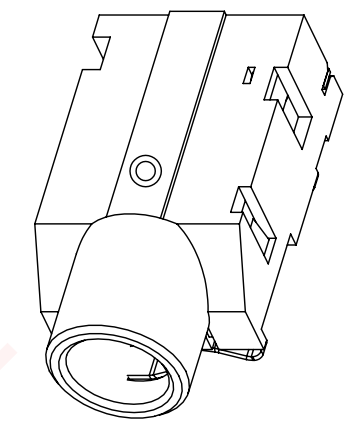

RECOMMENDED PCB LAYOUT
TOP VIEW (TOLERANCE: ±0.05)

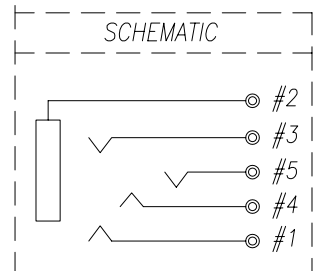
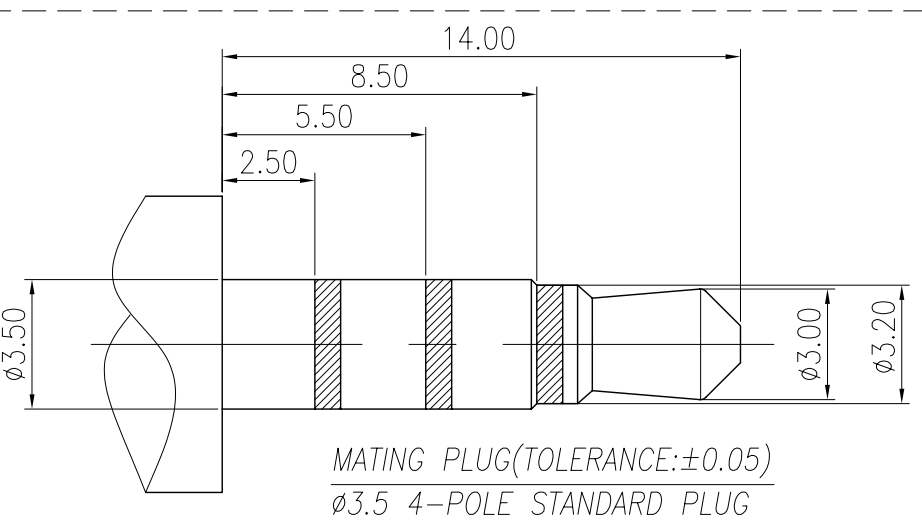

MATING PLUG (TOLERANCE: ±0.05)
ϕ3.5 4-POLE STANDARD PLUG

F	EARTH	1	COPPER ALLOY 0.2t	GOLD FLASH NICKEL UNDERPLATING
E	RING-B-2	1	COPPER ALLOY 0.2t	
D	RING-B-1	1	COPPER ALLOY 0.2t	
C	RING-A	1	COPPER ALLOY 0.2t	
B	TIP SPRING	1	COPPER ALLOY 0.2t	
A	BODY	1	HIGH TEMP.THERMOPLASTIC UL 94V-0	BLACK

NO	DESCRIPTION	QTY	MATERIAL	PLATING & COLOR
UNLESS OTHERWISE SPECIFIED TOLERANCES			Singatron Enterprise Co., Ltd. 信音企業股份有限公司	
DECIMALS:		TITLE		
X	:±0.5	ϕ3.5 PHONE JACK		
X.X	:±0.3	DWN	Xinrong-Tan 15/5/20	PART NO: 2SJ2287-001111F
X.XX	:±0.2	CHKD	Zhijun-Wei 15/5/20	SCALE 5:1 UNIT: mm
		APVD	Zjz-Zhou 15/5/20	SIZE: A4 SHEET: 10F1 REV: A

CUSTOMER COPY 15/05/20