

RECOMMENDED P.C.B. LAYOUT
TOP VIEW (TOLERANCE: ±0.05)

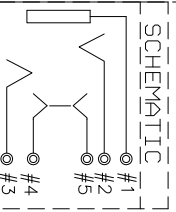
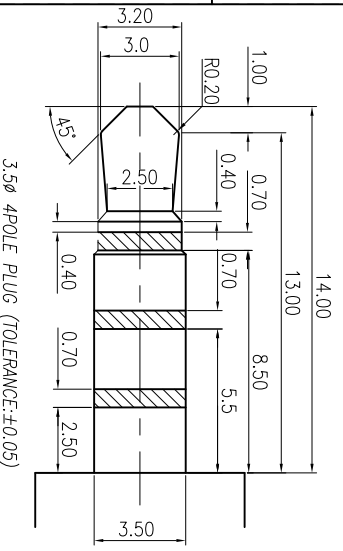

SPECIFICATIONS:

- ELECTRICAL CHARACTERISTICS:
 - 1-1. RATING: 12V 1A
 - 1-2. CONTACT RESISTANCE: $30m\Omega$ MAX.
 - 1-3. DIELECTRIC WITHSTANDING VOLTAGE: 500V AC FOR ONE MINUTE
 - 1-4. INSULATION RESISTANCE: $100M\Omega$ MIN. MEASURED BY 500 VDC
- MECHANICAL CHARACTERISTICS:
 - 2-1. INSERTION FORCE : 0.3~3.0 KGF
 - 2-2. WITHDRAWAL FORCE : 0.3~3.0 KGF
 3. LIFE TEST: 5,000 CYCLES MIN.
 4. OTHER GENERAL SPEC. TO REFER "2SU2300 SERIES SPEC".
 5. TO CONFORM TO THE SINGATRON HARDABRON SUBSTANCE FREE SPEC.
 6. HALOGEN FREE PRODUCT IDENTIFICATION MARK: ©
 7. HALOGEN FREE PRODUCT IDENTIFICATION LABEL ON PACKAGING: ©
 8. FOR REFLOW SOLDERING LEAD-FREE PROCESS.
 9. PACKAGING: TAPE & REEL.

E	EARTH	1	COPPER ALLOY 0.2t	GOLD FLASH
D	RING B	2	COPPER ALLOY 0.2t	GOLD FLASH
C	TIP-2 SPRING	1	COPPER ALLOY 0.2t	GOLD FLASH
B	TIP-1 SPRING	1	COPPER ALLOY 0.2t	GOLD FLASH
A	BODY	1	HIGH TEMP. THERMOPLASTIC	BLACK
NO	DESCRIPTION	QTY	MATERIAL	PLATING & COLOR

UNLESS OTHERWISE SPECIFIED TOLERANCES:
 Singatron Enterprise Co., Ltd.
 信音企業股份有限公司

TITLE: 3.5φ PHONE JACK

DWN: Sticky 2011.6.2 PART NO. 2SU2300-004111F

CHKD: Wtkan 2011.6.2 SCALE 5:1 UNIT: mm

APVD: Liao 2011.6.2 SIZE: A4 SHEET: 10F1 REV: A

CUSTOMER COPY