

2-CO.50

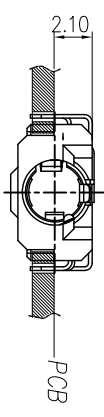
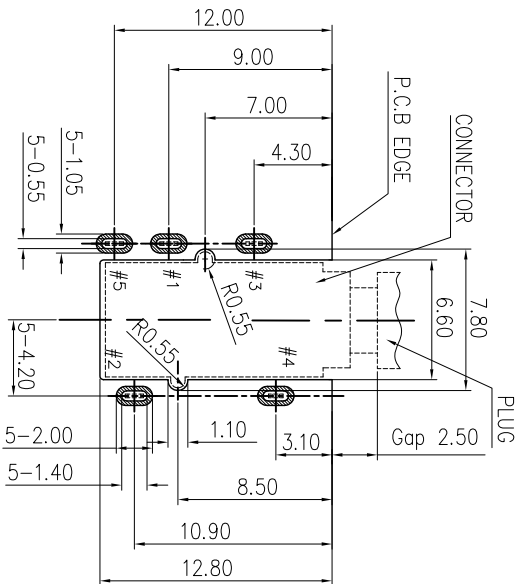

- SPECIFICATIONS:**
- ELECTRICAL CHARACTERISTICS:**
 - 1-1. RATING: 12V 1A
 - 1-2. CONTACT RESISTANCE: 30mΩ MAX(BEFORE)
 - 1-3. DIELECTRIC VOLTAGE WITHSTAND: 500V AC FOR ONE MINUTE
 - 1-4. INSULATION RESISTANCE: 100MΩ/MIN. MEASURED BY 500 VDC
 - MECHANICAL CHARACTERISTICS:**
 - 2-1. INSERTED FORCE : 0.3~3.0 kgf
 - 2-2. WITHDRAWAL FORCE : 0.3~3.0 kgf
 - LIFE TEST:** 5,000 CYCLES .
 - OTHERS TO CONFORM TO THE "2SJ2321SERIES" SPECIFICATION.**
 - HALOGEN FREE PRODUCT IDENTIFICATION MARK:**
 - HALOGEN FREE PRODUCT IDENTIFICATION LABEL ON PACKAGING:**
 - FOR REFLOW SOLDERING LEAD-FREE PROCESS.**
 - PACKAGING :** TAPE & REEL.

RECOMMENDED P.C.B. LAYOUT
TOP VIEW (TOLERANCE: ±0.05)

RECOMMENDED CHASSIS

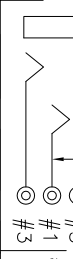
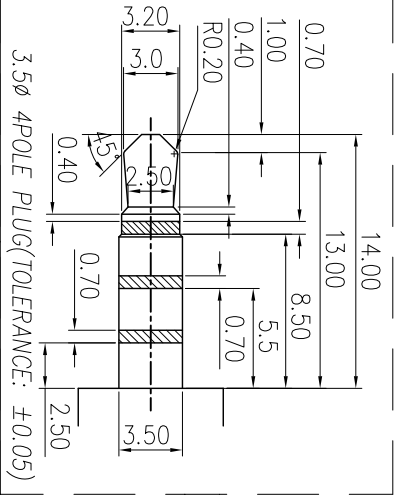
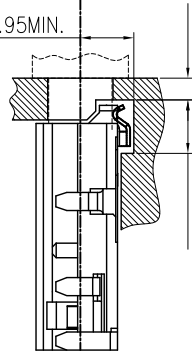
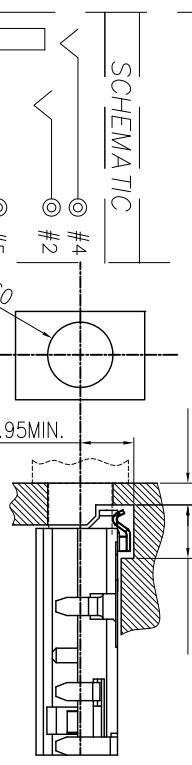

TOLERANCE: ±0.05

| NO | DESCRIPTION | QTY | MATERIAL | PLATING & COLOR |
|----|-------------|-----|-----------------------|----------------------------|
| F | RING-B | 1 | COPPER ALLOY 0.2t | |
| E | EARTH | 1 | COPPER ALLOY 0.2t | Gold flash on contact area |
| D | RING-A | 1 | COPPER ALLOY 0.2t | and solder tail |
| C | TIP | 1 | COPPER ALLOY 0.2t | All over Nickel Plated. |
| B | SHUNT | 1 | COPPER ALLOY 0.2t | |
| A | BODY | 1 | HI-TEMP THERMOPLASTIC | BLACK |

| | |
|---------------------------------------|----------|
| UNLESS OTHERWISE SPECIFIED TOLERANCES | |
| DECIMALS: | ANGLES: |
| X : ±0.5 | X : ±2° |
| XX : ±0.3 | XX : ±1° |
| XXX : ±0.2 | |

| | | |
|------|------------------|--------------------------|
| DWM | LAND 2012.12.05 | PART NO. 2SJ2321-020111F |
| CHKD | WIKAM 2012.12.05 | SCALE 3:1 |
| APVD | LJLW 2012.12.05 | UNIT: mm |
| | | SIZE: A3 |
| | | SHEET: 10/1 |
| | | REV: A |

Singatron Enterprise Co., Ltd.
信晉企業股份有限公司

Ø3.5 PHONE JACK

CUSTOMER COPY