

REV	ECN NO OR DESCRIPTION	REVISED	DATE
A	PRODUCT RELEASE	ZLS	2014.3.10
B	ECN NO.: C140032 UPDATE DATE CODE	ZLS	2014.7.11
C	ECN NO.: C140259 UPDATE TOLERANCE	ZLS	2014.12.12

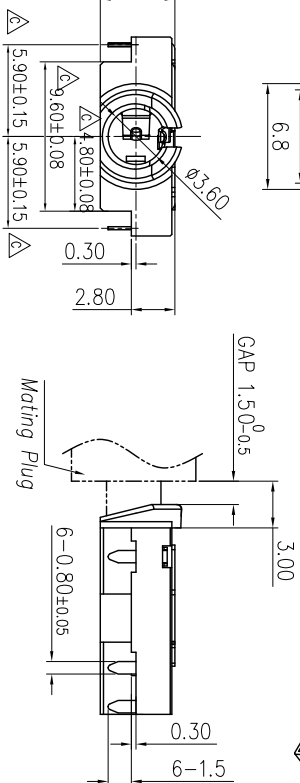

SPECIFICATIONS:

- ELECTRICAL CHARACTERISTICS:
 - RATING: 12V, 1A.
 - CONTACT RESISTANCE: 50mΩ MAX.
 - DIELECTRIC WITHSTANDING VOLTAGE: 500V AC FOR ONE MINUTE.
 - INSULATION RESISTANCE: 100 MEGOHMS BY 500V DC.
- MECHANICAL CHARACTERISTICS:
 - INSERTION FORCE: 0.4~3.0 KGf
 - WITHDRAWAL FORCE: 0.3~2.0 KGf
- LIFE TEST: 5,000 CYCLES.
- OTHER GENERAL SPEC.: TO REFER "2SJ2326 SERIES SPEC".
- TO CONFORM TO THE SINGATRON HAZARDOUS SUBSTANCE FREE SPEC.
- HALOGEN FREE PRODUCT IDENTIFICATION MARK ON JACK:
- HALOGEN FREE PRODUCT IDENTIFICATION LABEL ON PACKAGING:
- FOR REFLOW SOLDERING LEAD-FREE PROCESS.
- PACKAGING: TAPE & REEL.

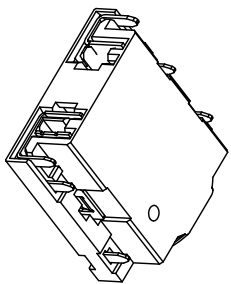
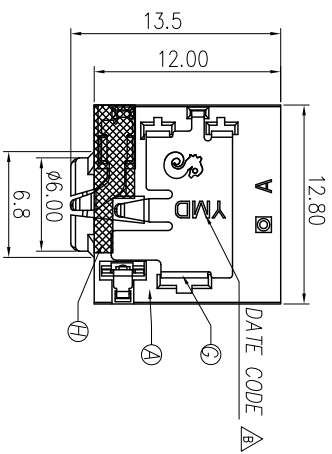
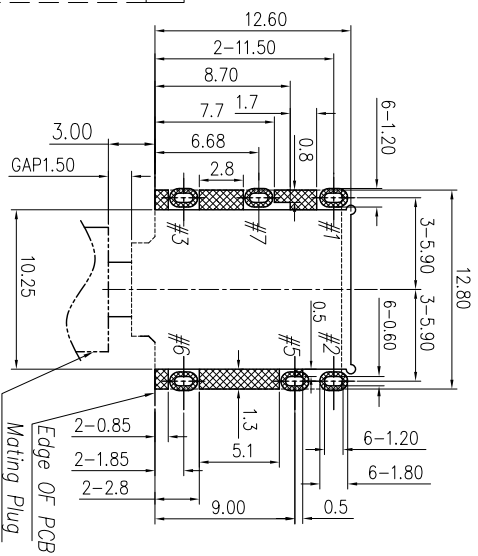
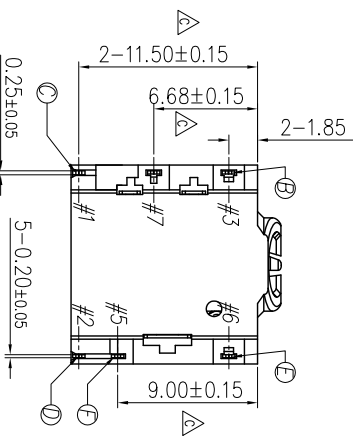

RECOMMENDED P.C.B. LAYOUT T=1.20
TOP VIEW (TOLERANCE: ±0.05)

STAND OFF

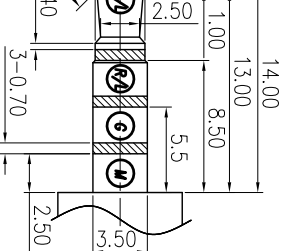
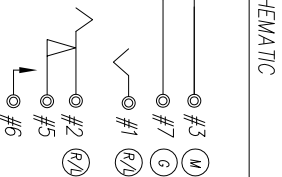

NO	DESCRIPTION	QTY	MATERIAL	PLATING & COLOR
A	BODY	1	PA101+30%GF UL 94V-0	BLACK
B	EARTH	1	COPPER ALLOY 0.20T	Gold Flash
C	TIP	1	COPPER ALLOY 0.25T	Gold Flash on contact area and Solder fill all over Nickel Plated
D	RING	1	COPPER ALLOY 0.20T	Gold Flash on contact area and Solder fill all over Nickel Plated
E	MAKE TERMINAL	1	COPPER ALLOY 0.20T	Gold flash on contact area and Solder fill all over Nickel Plated
F	TRANSFER TERMINAL	1	COPPER ALLOY 0.20T	Gold flash on contact area and Solder fill all over Nickel Plated
G	SHIELD	1	COPPER ALLOY 0.20T	Gold flash on contact area all over Nickel Plated
H	MYLAR	1	THICKNESS 0.075T	YELLOW

UNLESS OTHERWISE SPECIFIED TOLERANCES

Singatron Enterprise Co., Ltd.
信音企業股份有限公司

TITLE: 3.50 PHONE JACK

DWN: ZLS 14/12/23 PART NO. 2SJ2326-043111F

CHKD: BILLY 14/12/23 SCALE 3:1 UNIT: mm

APVD: ZLZ 14/12/23 SIZE: A3 SHEET: 10F1 REV: C

CUSTOMER COPY