

RECOMMENDED PCB LAYOUT  
TOP VIEW (TOLERANCE: ±0.05)

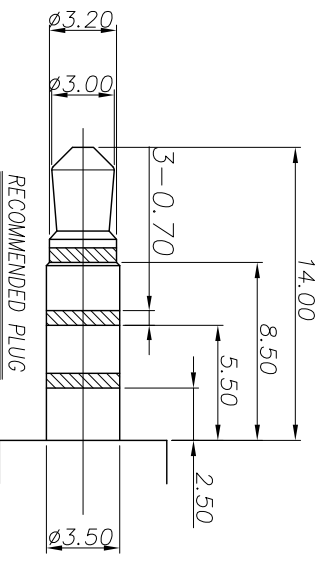

RECOMMENDED PLUG  
4-POLE

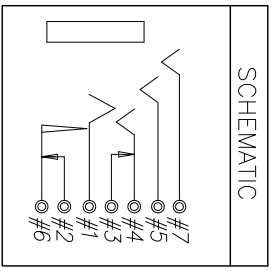

SCHEMATIC

REV.	ECN NO.	OR DESCRIPTION	REVISED	DATE
C	ECN NO. S100226	Allen	2010.02.26	
D	ECN NO. S100420	Allen	2010.06.02	
E	ECN NO. S120750	SEAN	2012.07.31	

- SPECIFICATIONS:
- INSULATION RESISTANCE BETWEEN ANY ADJACENT OPEN CIRCUIT TERMINAL SHELL NOT BE LESS THAN 100MΩ MEASURED BY 500 VDC MEGGER.
  - CONTACT RESISTANCE: 30mΩ MAX.
  - INSULATION VOLTAGE WITHSTAND : 500V AC FOR ONE MINUTE.
  - UNLESS OTHERWISE SPECIFIED, TEST IS TO BE MADE AT 5-35°C IN TEMPERATURE AND 45-88% IN HUMIDITY. BUT, IF ANY VAGUE DATA IS OCCURED ON TEST RESULT, ANOTHER TEST SHALL BE MADE AT 20°C±2°C IN TEMP., 60-70% IN HUMIDITY.
  - LIFE TEST: 5,000 CYCLES MIN. (NON-LOAD)
  - INSERTION FORCE: 0.4 - 3kgf.
  - WITHDRAWAL FORCE: 0.3 - 2kgf.
  - AFTER LIFE TEST, CONTACT RESISTANCE: 50mΩ MAX.
  - AFTER HUMIDITY TEST, INSULATION RESISTANCE: 50MΩ MIN.
  - MARKING: MARK "S" ON TOP OF CONNECTOR.
  - PACKAGING : TAPE & REEL.
  - TO CONFORM TO SINGATRON HAZARDOUS SUBSTANCE FREE SPEC.
  - HALOGEN FREE PRODUCT IDENTIFICATION MARK ON PRODUCT: Ⓢ
  - HALOGEN FREE PRODUCT IDENTIFICATION LABEL ON PACKAGING: Ⓢ
  - FOR LEAD-FREE PROCESS.

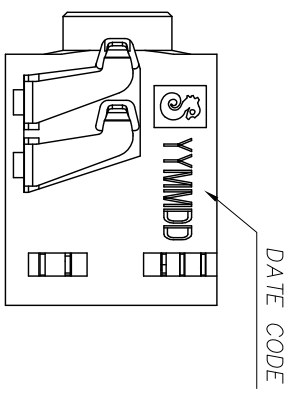

DATE CODE

G	BREAK TERMINAL	1	BRASS 0.2t	GOLD FLASH OVER IN 500 <sup>th</sup> Mm.
F	SHUNT TERMINAL-A	1	BRASS 0.2t	GOLD FLASH OVER IN 500 <sup>th</sup> Mm.
E	RING SPRING	1	PHOSPHOR BRONZE 0.2t	GOLD FLASH OVER IN 500 <sup>th</sup> Mm.
D	TIP SPRING	1	PHOSPHOR BRONZE 0.25t	GOLD FLASH OVER IN 500 <sup>th</sup> Mm.
C	EARTH	2	PHOSPHOR BRONZE 0.2t	GOLD FLASH OVER IN 500 <sup>th</sup> Mm.
B	TRANSFER TERMINAL	1	PHOSPHOR BRONZE 0.2t	GOLD FLASH OVER IN 500 <sup>th</sup> Mm.
A	BODY	1	HIGH TEMP. UL 94Y-0	BLACK 7C
NO	DESCRIPTION	QTY	MATERIAL	PLATING & COLOR

UNLESS OTHERWISE SPECIFIED TOLERANCES

DECIMALS: ANGLES:

X : ±0.5 X : ±2°  
 X.X : ±0.3 X.X : ±1'  
 X.XX : ±0.2

TITLE	3.5φ PHONE JACK
DWN	SEAN PART NO. 2SJ3005-004211
CHKD	TOM SCALE: 4/1 UNIT: mm
APVD	QUAN SIZE: A3 SHEET: 10F1 REV: E

CUSTOMER COPY

Singatron Enterprise Co., Ltd.  
 信音企業股份有限公司