

REV.	ECN NO OR DESCRIPTION	REVISED	DATE
A	PDR NO.T100819-8A	DengFeng	2011.05.04
B	ECN NO.S150703-C	JIE-FU	2015.09.09

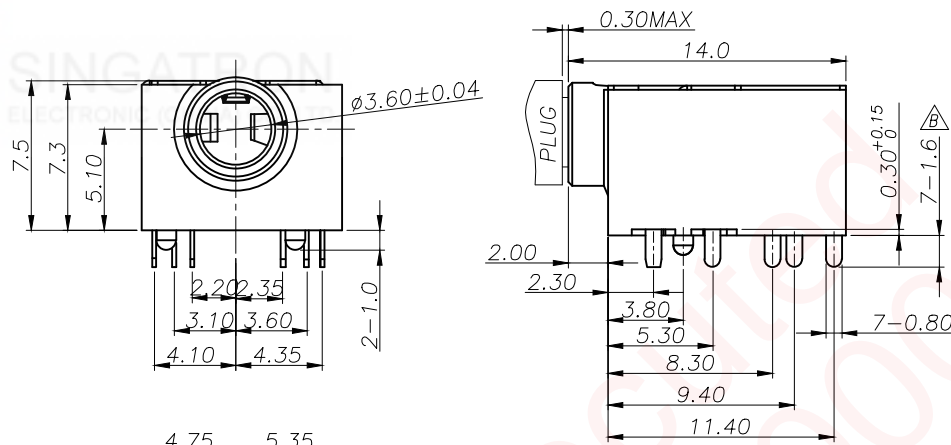

SPECIFICATIONS:

- ELECTRICAL CHARACTERISTICS:**
 - 1-1. RATING: 12V 1A
 - 1-2. CONTACT RESISTANCE: 30mΩ MAX.(INITIAL)
 - 1-3. DIELECTRIC WITHSTANDING VOLTAGE: 500V AC FOR ONE MINUTE
 - 1-4. INSULATION RESISTANCE: 100MΩ MIN. MEASURED BY 500 VDC
- MECHANICAL CHARACTERISTICS:**
 - 2-1. INSERTION FORCE : 0.3~3.0 KGF
 - 2-2. WITHDRAWAL FORCE : 0.3~3.0 KGF
- LIFE TEST: 5,000 CYCLES MIN.**
- OTHER GENERAL SPEC. TO REFER "2SJ3005 SERIES SPEC".**
- TO CONFORM TO SINGATRON HAZARDOUS SUBSTANCE FREE SPEC.**
- HALOGEN FREE PRODUCT IDENTIFICATION MARK ON JACK: Ⓢ**
- HALOGEN FREE PRODUCT IDENTIFICATION LABEL ON PACKAGING: Ⓢ**
- FOR REFLOW SOLDERING LEAD-FREE PROCESS.**

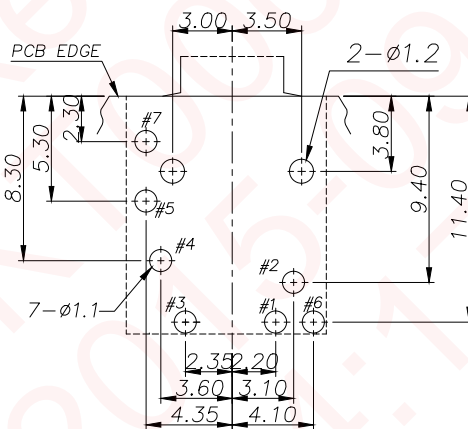
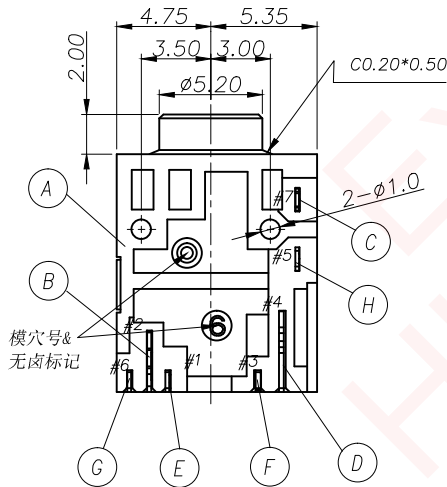

RECOMMENDED PCB LAYOUT
TOP VIEW (TOLERANCE: ±0.05)

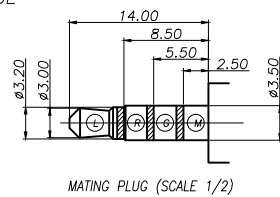
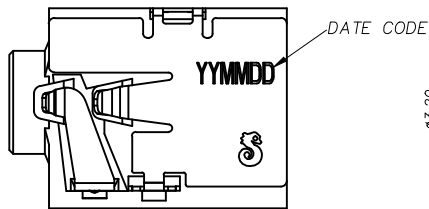

MATING PLUG (SCALE 1/2)

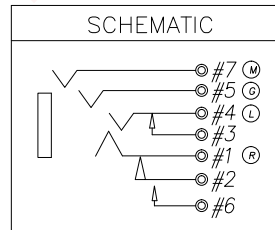

NO	DESCRIPTION	QTY	MATERIAL	PLATING & COLOR
H	SHELL	1	PHOSPHOR BRONZE 0.3t	GOLD FLASH ON CONTACT AREA , Matte Sn 100u" ON SOLDERING AREA, ALL OVER Ni 50u"Min.
G	BREAK TERMINAL	1	PHOSPHOR BRONZE 0.2t	
F	SHUNT TERMINAL-A	1	BRASS 0.2t	
E	RING SPRING	1	PHOSPHOR BRONZE 0.2t	
D	TIP SPRING	1	PHOSPHOR BRONZE 0.25t	
C	EARTH	1	PHOSPHOR BRONZE 0.2t	
B	TRANSFER TERMINAL	1	PHOSPHOR BRONZE 0.2t	
A	BODY	1	HIGH TEMP.UL 94V-0	BLACK 7C

UNLESS OTHERWISE SPECIFIED TOLERANCES

Singatron Enterprise Co., Ltd.
信音企業股份有限公司

DECIMALS: ANGLES:
X :±0.5 X :±2°
X.X :±0.3 X.X :±1°
X.XX :±0.2

TITLE	3.5Φ PHONE JACK			
DWN	JIE-FU	PART NO.	2SJ3005-009211	
CHKD	CERRY	SCALE:1:1	UNIT: mm	Ⓢ
APVD	LIAO	SIZE: A3	SHEET: 10F1	REV:B

CUSTOMER COPY