

REV.	ECN NO OR DESCRIPTION	REVISED	DATE
A	PDR NO.:T111216-5A	Swing	2012.03.05
B	ECN NO.:S120817	Cerry	2012.11.28

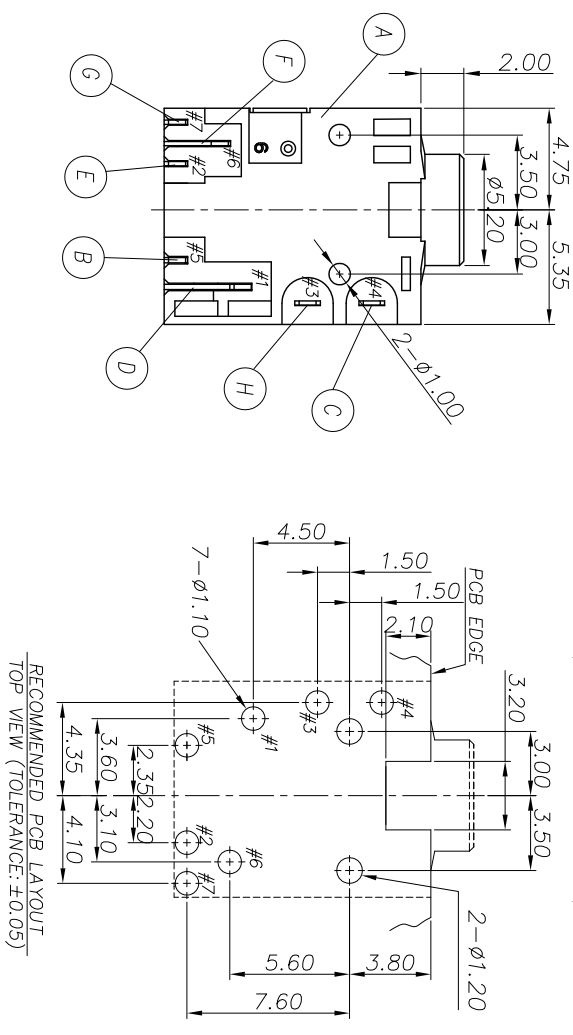

RECOMMENDED PCB LAYOUT
TOP VIEW (TOLERANCE: ±0.05)

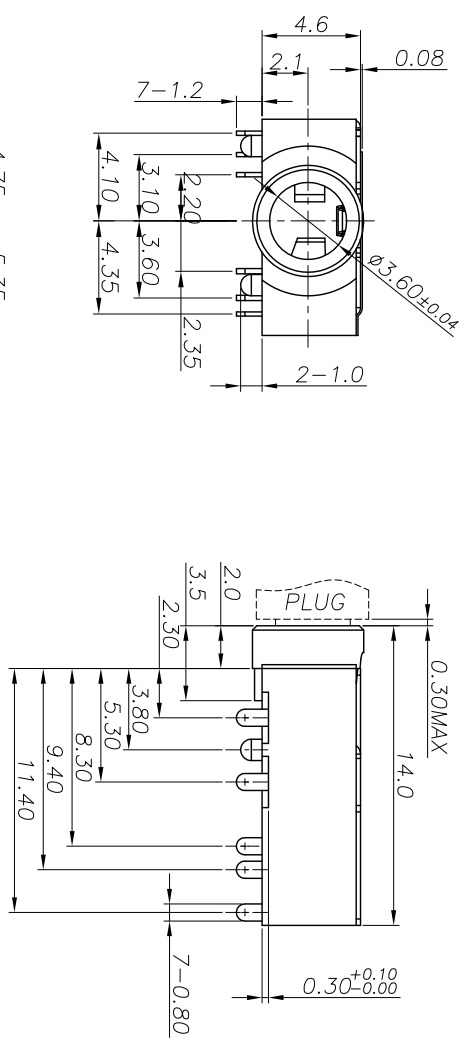
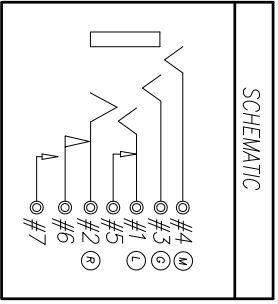
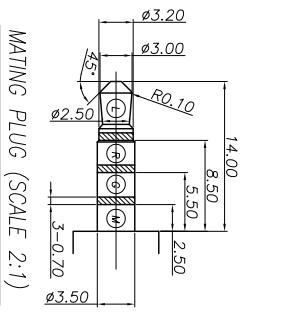
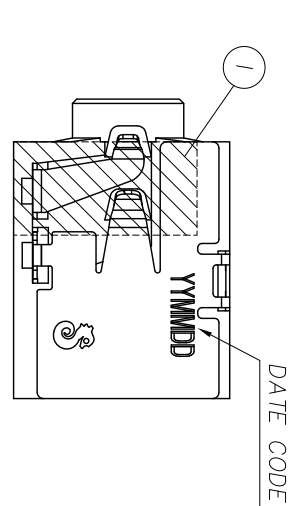

- SPECIFICATIONS:
- ELECTRICAL CHARACTERISTICS:
 - RATING: 12V 1A
 - CONTACT RESISTANCE: 30mΩ MAX (INITIAL)
 - DIELECTRIC WITHSTANDING VOLTAGE: 500V AC FOR ONE MINUTE
 - INSULATION RESISTANCE: 100MΩ MIN. MEASURED BY 500V DC
 - MECHANICAL CHARACTERISTICS:
 - INSERTION FORCE : 0.3~3.0 KGF
 - WITHDRAWAL FORCE : 0.3~3.0 KGF
 - LIFE TEST: 5,000 CYCLES MIN.
 - OTHER GENERAL SPEC. TO REFER "2SJ3005 SERIES SPEC."
 - TO CONFORM TO SINGATRON HAZARDOUS SUBSTANCE FREE SPEC.
 - HALOGEN FREE PRODUCT IDENTIFICATION MARK ON JACK:
 - HALOGEN FREE PRODUCT IDENTIFICATION LABEL ON PACKAGING:
 - FOR REFLOW SOLDERING LEAD-FREE PROCESS.

I	MAILAY	1	INSULATION FILM	YELLOW
H	SHELL	1	PHOSPHOR BRONZE 0.2T	GOLD FLASH ON CONTACT AREA
G	BREAK TERMINAL	1	PHOSPHOR BRONZE 0.2T	MATE 5μ 120μ" ON SOLDER AREA
F	TRANSFER TERMINAL	1	PHOSPHOR BRONZE 0.2T	ALL OVER N° 50μ" MIN.
E	RING SPRING	1	PHOSPHOR BRONZE 0.2T	
D	TIP SPRING	1	PHOSPHOR BRONZE 0.25T	
C	EARTH	1	PHOSPHOR BRONZE 0.2T	GOLD FLASH OVER N° 50μ" Min.
B	SHUNT TERMINAL-A	1	BRASS 0.2T	
A	BODY	1	HIGH TEMP.U/L 94V-0	BLACK
NO	DESCRIPTION	QTY	MATERIAL	PLATING & COLOR

UNLESS OTHERWISE SPECIFIED TOLERANCES

Singatron Enterprise Co., Ltd.
信音企業股份有限公司

TITLE: 3.5Φ PHONE JACK

DWN: Cerry PART NO. 2SJ3005-019111F

CHKD: Tom SCALE: 4:1 UNIT: mm

APVD: Max SIZE: A3 SHEET: 1 OF 1 REV: B

DECIMALS:	ANGLES:
X : ±0.5	X : ±2°
X.X : ±0.3	X.X : ±1°
X.XX : ±0.2	

CUSTOMER COPY