

| | | | |
|------|-----------------------|---------|------------|
| REV. | ECN NO OR DESCRIPTION | REVISED | DATE |
| A | PDR NO :T130204-5A | ROBIN | 2013.06.20 |

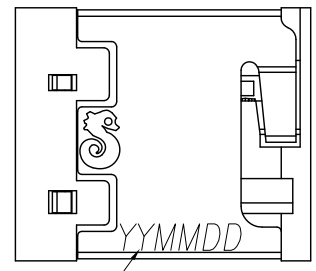

- SPECIFICATIONS:**
- INSULATION RESISTANCE BETWEEN ANY ADJACENT OPEN CIRCUIT TERMINAL SHELL NOT BE LESS THAN 100MΩ MEASURED BY 500V DC .
 - CONTACT RESISTANCE: 50mΩ MAX.
 - INSULATION VOLTAGE WITHSTAND:500V AC FOR ONE MINUTE.
 - UNLESS OTHERWISE SPECIFIED. TEST IS TO BE MADE AT 5-35°C IN TEMPERATURE AND 45-85% IN HUMIDITY. BUT,IF ANY VAGUE DATA IS OCCURED ON TEST RESULT, ANOTHER TEST SHALL BE MADE AT 20°C±2°C IN TEMP., 60-70% IN HUMIDITY.
 - LIFE TEST: 5,000 CYCLES.
 - INSERTION FORCE: 0.3 - 3.0Kgf.
 - WITHDRAWAL FORCE: 0.3 - 3.0Kgf.
 - AFTER LIFE TEST, CONTACT RESISTANCE: 100mΩ MAX.
 - AFTER HUMIDITY TEST, INSULATION RESISTANCE: 50MΩ MIN.
 - MARKING: MARK "S" ON TOP OF CONNECTOR.
 - PACKING : TAPE & REEL.
 - TO CONFORM TO SINGATRON HAZARDOUS SUBSTANCE FREE SPEC.
 - HALOGEN FREE PRODUCT IDENTIFICATION MARK ON JACK:
 - HALOGEN FREE PRODUCT IDENTIFICATION LABEL ON PACKAGING:
 - FOR LEAD-FREE PROCESS.

RECOMMENDED PCB LAYOUT
TOP VIEW ; TOL.±0.05

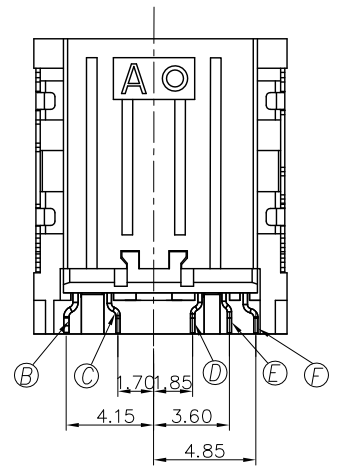
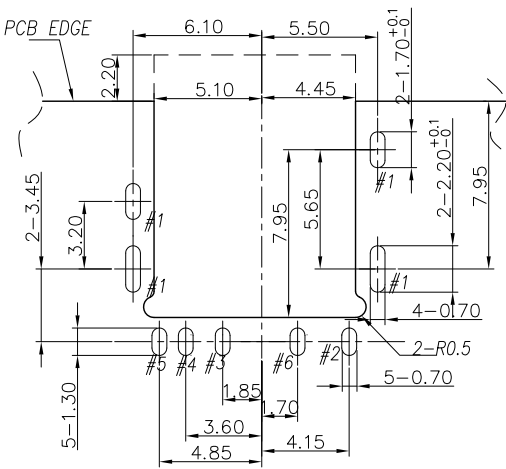
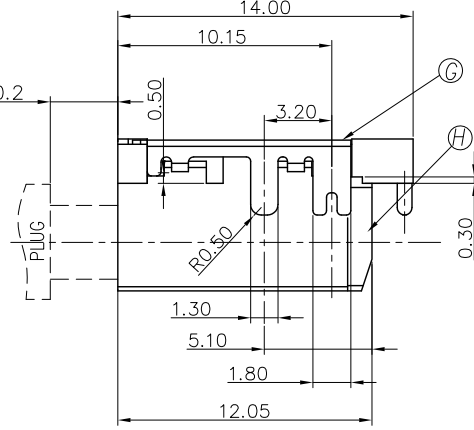
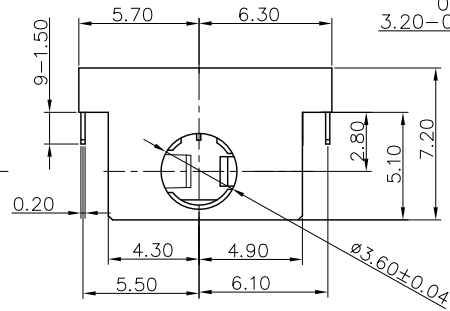
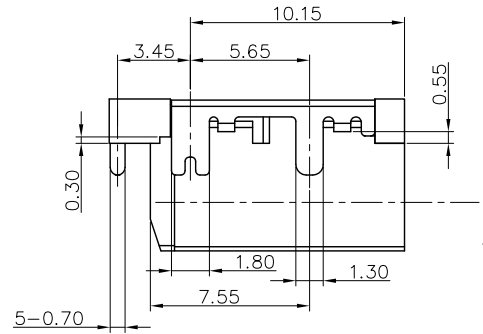
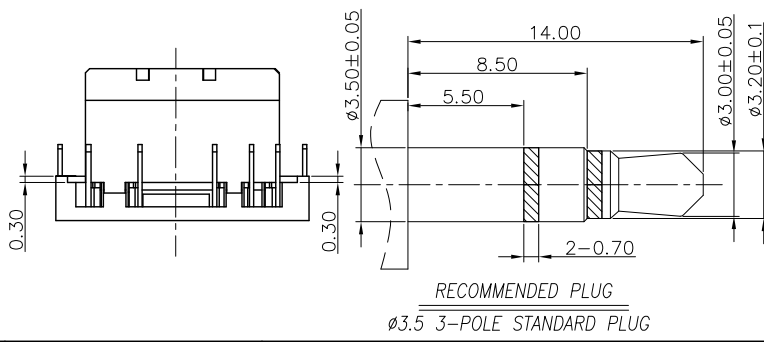
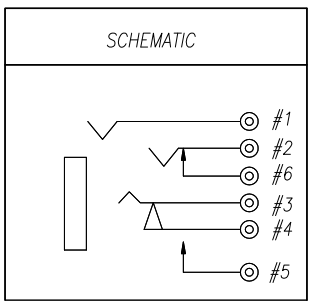

| NO | DESCRIPTION | QTY | MATERIAL | PLATING & COLOR |
|----|-------------------|-----|----------------------------------|---|
| H | COVER | 1 | HIGH TEMP.THERMOPLASTIC UL 94V-0 | BLACK |
| G | SHELL&EARTH | 1 | PHOSPHOR BRONZE 0.2t | GOLD FLASH ON CONTACT AREA OVER Ni 60u" Min. |
| F | MAKE TERMINAL | 1 | PHOSPHOR BRONZE 0.2t | |
| E | TRANSFER TERMINAL | 1 | PHOSPHOR BRONZE 0.2t | GOLD FLASH ON CONTACT AREA & SOLDER TAIL ALL OVER |
| D | RING SPRING | 1 | PHOSPHOR BRONZE 0.2t | |
| C | SHUNT TERMINAL | 1 | COPPER ALLOY 0.2t | Ni 60u"Min. |
| B | TIP SPRING | 1 | PHOSPHOR BRONZE 0.25t | |
| A | BODY | 1 | HIGH TEMP.THERMOPLASTIC UL 94V-0 | BLACK |

UNLESS OTHERWISE SPECIFIED TOLERANCES

DECIMALS: X :±0.5 X.X :±0.3 X.XX :±0.2

ANGLES: X :±2' X.X :±1'

TITLE: **3.5φ PHONE JACK**

DWN ROBIN PART NO.2SJ3013-022311F

CHKD Bruce SCALE:4:1 UNIT: mm

APVD Lussen SIZE: A3 SHEET:1 OF 1 REV: A

Singatron Enterprise Co., Ltd.
信音企業股份有限公司

CUSTOMER COPY