

REV.	ECN NO OR DESCRIPTION	REVISED	DATE
A	PDR:T090714-8A/8B	BRUCE	2009.09.21

**SPECIFICATIONS:**

1. ELECTRICAL CHARACTERISTICS:
  - 1-1. RATING: 12V 1A Max.
  - 1-2. CONTACT RESISTANCE: 30mΩ MAX(INITIAL).
  - 1-3. DIELECTRIC WITHSTANDING VOLTAGE:500V AC FOR ONE MINUTE
  - 1-4. INSULATION RESISTANCE: 100MΩ MIN. MEASURED BY 500 VDC
2. MECHANICAL CHARACTERISTICS:
  - 2-1. INSERTION FORCE : 0.4~3.0 KGF
  - 2-2. WITHDRAWAL FORCE : 0.4 KGF Min.
3. LIFE CYCLES: 5,000 CYCLES
4. PACKING: TAPE & REEL
5. TO CONFORM TO SINGATRON HAZARDOUS SUBSTANCE FREE SPEC.
6. GREEN PRODUCT IDENTIFICATION MARK ON JACK:
7. GREEN PRODUCT IDENTIFICATION LABEL ON PACKAGING:
8. FOR REFLOW SOLDERING LEAD-FREE PROCESS.

RECOMMENDED PLUG(SCALE 2.0:1) TOL.±0.05mm

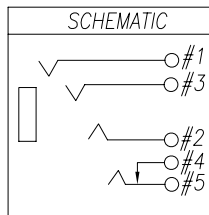
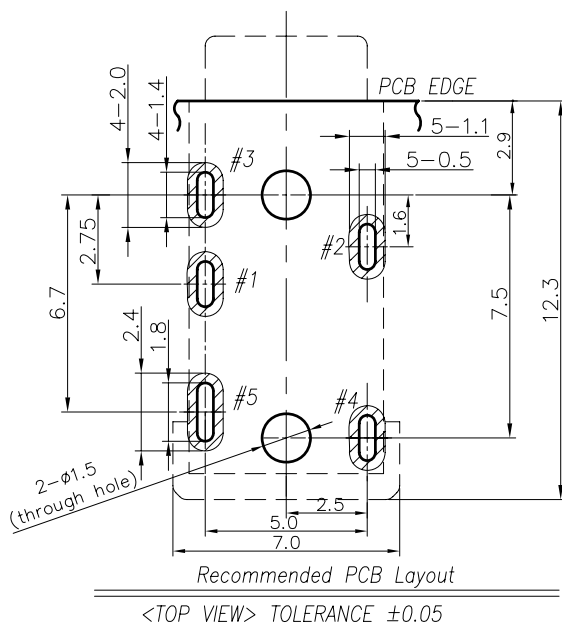
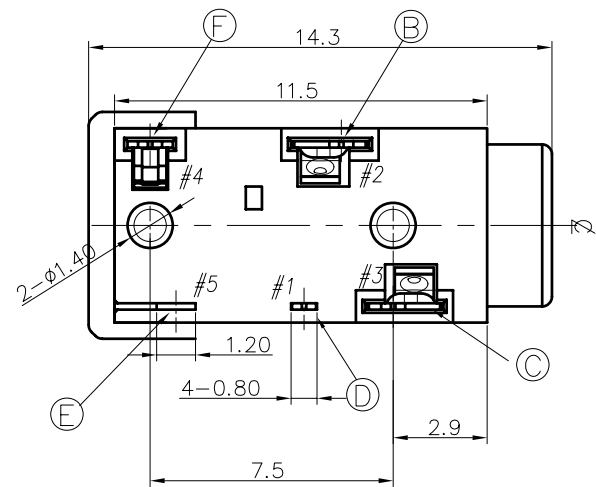
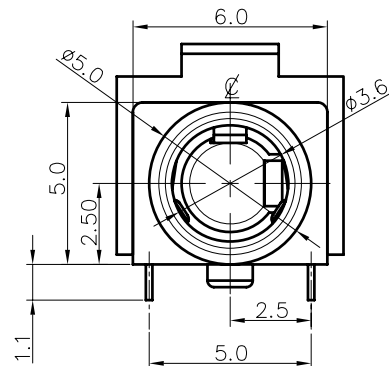
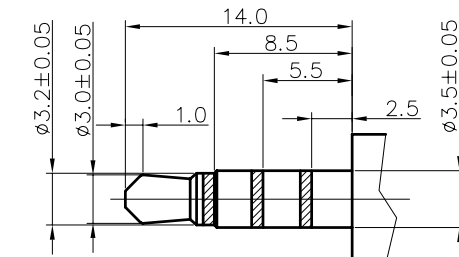
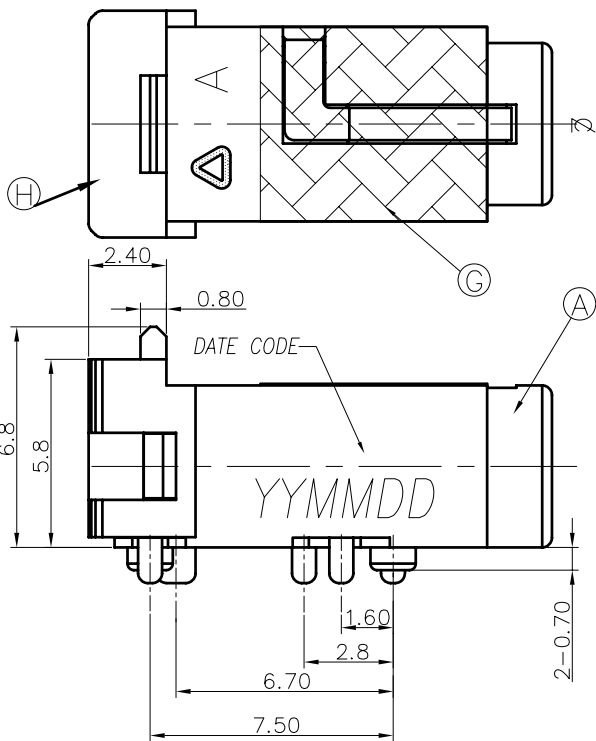

"TABLE 1"

COLOR	P/N
BLACK	2SJ3014-001111
RED (PAN.#1807C)	2SJ3014-001171

NO	DESCRIPTION	QTY	MATERIAL	PLATING & COLOR
H	COVER	1	HIGH TEMP.THERMOPLASTIC UL 94V-0	BLACK
G	MYLAR	1	MYLAR 0.075t	
F	SHUNT	1	PHOSPHOR BRONZE 0.2t	GOLD FLASH
E	TIP	1	PHOSPHOR BRONZE 0.2t	GOLD FLASH
D	EARTH SPRING	1	PHOSPHOR BRONZE 0.2t	GOLD FLASH
C	RING SPRING B	1	PHOSPHOR BRONZE 0.2t	GOLD FLASH
B	RING SPRING A	1	PHOSPHOR BRONZE 0.2t	GOLD FLASH
A	BODY	1	HIGH TEMP.THERMOPLASTIC UL 94V-0	SEE "TABLE 1"

UNLESS OTHERWISE SPECIFIED TOLERANCES		Singatron Enterprise Co., Ltd. 信音企業股份有限公司	
DECIMALS:	ANGLES:	TITLE	<b>3.5φ PHONE JACK(4-POLE)</b>
X : ±0.5	X : ±2°	DWN	BRUCE 2009.09.21 PART NO.: 2SJ3014-0011X1
X.X : ±0.3	X.X : ±1°	CHKD	BOYE 2009.09.21 SCALE 5:1 UNIT: mm
X.XX : ±0.2		APVD	MAX 2009.09.21 SIZE: A3 SHEET:1 OF 1 REV:A
<b>CUSTOMER COPY</b>			