

1 2 3 4 5 6 7 8

REV.	ECN NO OR DESCRIPTION	REVISED	DATE
A	PDR RELEASE	Even	2013.05.24
B	ECN NO:L130157	Even	2013.11.08
C	ECN NO.L202112-001	Even	2022.06.06

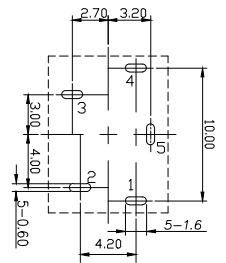

RECOMMENDED P.C.B LAYOUT
TOLERANCE: ±0.1MM(BOTTOM VIEW)

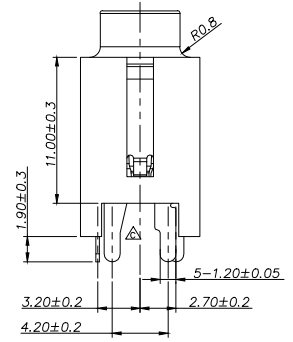
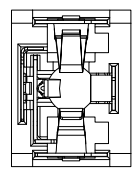
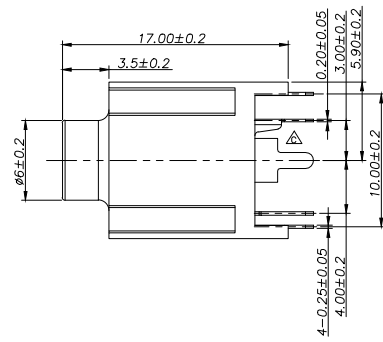
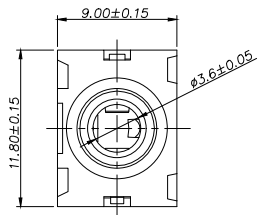
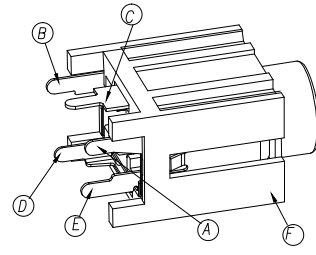
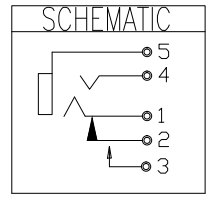
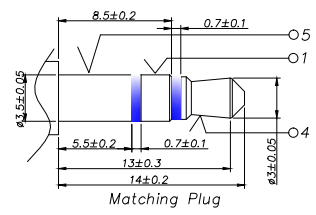
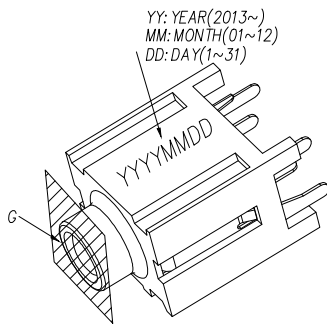

SPECIFICATIONS:

- ELECTRICAL CHARACTERISTICS:
 - CURRENT RATING: 0.5 AMP.
 - VOLTAGE RATING: 30V.
 - CONTACT RESISTANCE: 30mΩ MAX.
 - INSULATION RESISTANCE: 100MΩ MIN. @ 500V DC.
 - DIELECTRIC WITHSTANDING VOLTAGE: 500V AC FOR 1 MINUTE.
- MECHANICAL CHARACTERISTICS:
 - INSERTION FORCE: 0.4~3.0 Kgf.
 - WITHDRAWAL FORCE: 0.4~3.0 Kgf.
- LIFE TEST: 5,000 CYCLES.
- OTHER GENERAL SPEC. TO REFER "2SJ3017-010311 SPEC".
- TO CONFORM TO THE SINGATRON HAZARDOUS SUBSTANCE FREE SPEC.
- HALOGEN FREE PRODUCT IDENTIFICATION LABEL ON PACKAGING.
- PACKAGE: SEE "2SJ3017-010311" PACKAGE.
- FOR REFLOW SOLDERING LEAD-FREE PROCESS.

PART NO.

2SJ3017-010311

- PACKAGE: 1: TAPE & REEL, CARRIER WIDTH=32mm
- HOUSING COLOR: 1: BLACK
- CONTACT PLATING: 3: GOLD FLASH ON CONTACT AREA, 100u" MATTE TIN PLATING ON SOLDER AREA, 50u" NICKEL UNDER PLATING OVERALL

NO	DESCRIPTION	QTY	MATERIAL	PLATING & COLOR
G	MYLAR		KAPTON	YELLOW
F	HOUSING	1	PA-6T UL 94V-0	BLACK
E	CONTACT #2	1	PHOSPHOR BRONZE	GOLD FLASH ON OVERALL
D	CONTACT #3	1	PHOSPHOR BRONZE	SEE PART NO.
C	CONTACT #5	1	PHOSPHOR BRONZE	SEE PART NO.
B	CONTACT #4	1	PHOSPHOR BRONZE	SEE PART NO.
A	CONTACT #1	1	PHOSPHOR BRONZE	SEE PART NO.

UNLESS OTHERWISE SPECIFIED TOLERANCES		信音科技(香港)有限公司		
DECIMALS:	ANGLES:	TITLE	Ø3.5MM AUDIO JACK, VERTICAL TYPE, OUTER DIA=6.0MM	
X : ±0.5	X : ±2°	DWN	Even 2022.06.06	PART NO. 2SJ3017-010311
X.X : ±0.3	X.X : ±1°	CHKD	SCALE 1:1	UNIT: mm
X.XX : ±0.2		APVD	ANGELA 2022.06.06	SIZE: A3 SHEET: 1 OF 1 REV:C
CUSTOMER COPY				