

- PICK & PLACE AREA(Ø3.50)
DATE CODE
YYMMDD.
- 3.50 4POLE PLUG(TOLERANCE: ±0.05)
- SPECIFICATIONS:
- ELECTRICAL CHARACTERISTICS:
 - RATING: 12V 1A
 - CONTACT RESISTANCE: 30mΩ MAX.(INITIAL)
 - DIELECTRIC WITHSTANDING VOLTAGE: 500V AC FOR ONE MINUTE.
 - INSULATION RESISTANCE: 100MΩ MIN. MEASURED BY 500 VDC
 - MECHANICAL CHARACTERISTICS:
 - INSERTION FORCE : 0.3~3.0 KGF
 - WITHDRAWAL FORCE : 0.2~2.0 KGF
 - LIFE TEST: 5,000 CYCLES MIN.
 - OTHER GENERAL SPEC. TO REFER "
 - TO CONFORM TO SINGATRON HAZARDOUS SUBSTANCE FREE SPEC.
 - HALOGEN FREE PRODUCT IDENTIFICATION MARK ON PRODUCT: ☉
 - HALOGEN FREE PRODUCT IDENTIFICATION LOGO ON PACKAGING: Ⓢ
 - FOR REFLOW SOLDERING LEAD-FREE PROCESS.
 - PLEASE PUT THE PRODUCT IN A CONDITION WHERE IS FULL OF NITROGEN WHEN PASS THE IR REFLOW

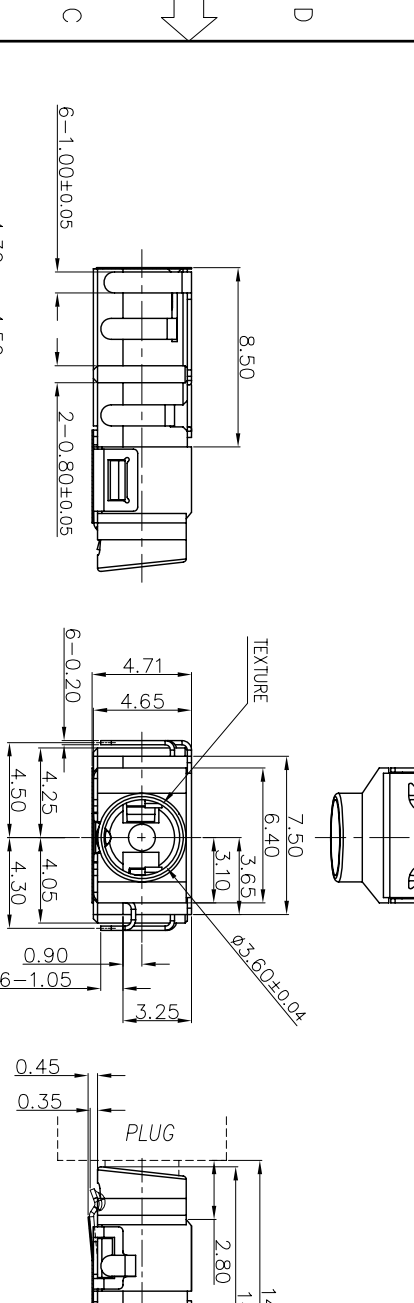

NO	DESCRIPTION	QTY	MATERIAL	PLATING & COLOR
A	BODY	1	HIgh TEMP. THERMOPLASTIC UL 94V-0	GRAY(PMS Cool Gray 6C)
B	EARTH	1	PHOSPHOR BRONZE 0.20T	
C	L-RING-B	1	PHOSPHOR BRONZE 0.20T	ALL OVER IN 50u"
D	R-RING-B	1	PHOSPHOR BRONZE 0.20T	GOLD FLASH ON CONTACT AREA; MATE IN 120u" ON SOLDER TAIL AREA;
E	RING-A	1	PHOSPHOR BRONZE 0.20T	
F	TIP SPRING	1	PHOSPHOR BRONZE 0.20T	GOLD FLASH ON CONTACT AREA; ALL OVER IN 50u"
G	SHELL	1	PHOSPHOR BRONZE 0.20T	Ni 50u" Min.
H	MYLAR	1	KAPTON T=0.06 6.4*5.0	YELLOW
I	MYLAR	1	KAPTON T=0.06 7.5*4.5	YELLOW

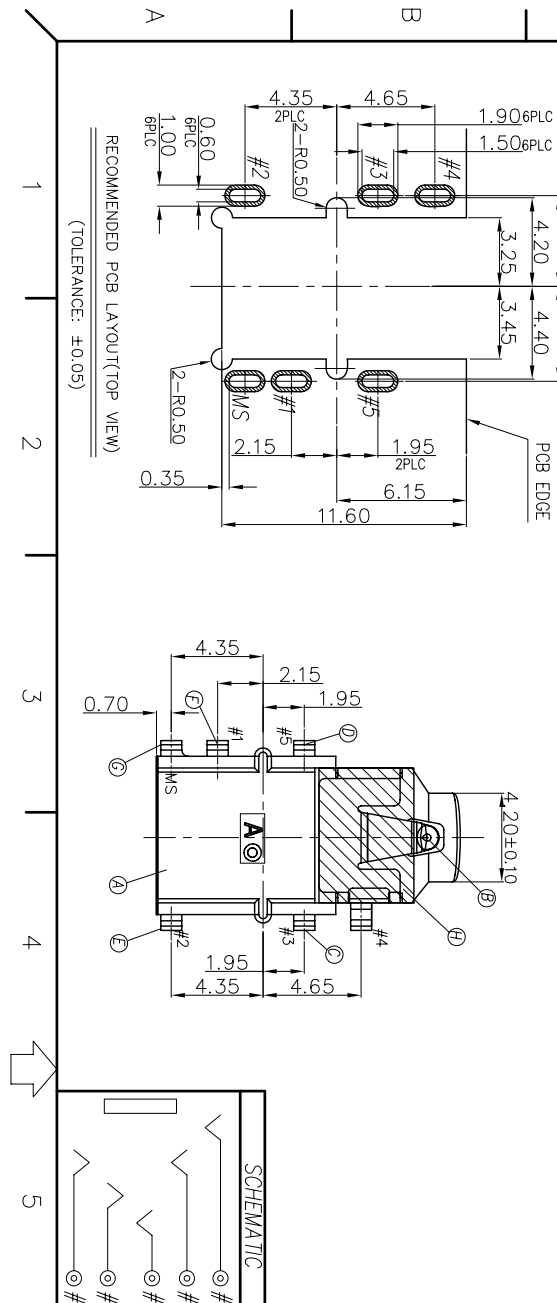

REV.	ECN NO OR DESCRIPTION	REVISED	DATE
A	PDR NO: T111110-9A	Swina	2012.04.03
B	ECN NO: S120668	Cerry	2012.07.27

DECIMALS:	ANGLES:
X : ±0.5	X : ±2°
X.X : ±0.3	X.X : ±1'
X.XX : ±0.2	

TITLE	PART NO.	SCALE:	UNIT:	SHEET:	REV:
03.50 AUDIO JACK	2S13035-011111F	4:1	mm	1 OF 1	B

SINGATRON ENTERPRISE CO., LTD.
信晉企業股份有限公司

CUSTOMER COPY