

3.50 4POLE PLUG(TOLERANCE: ±0.05)

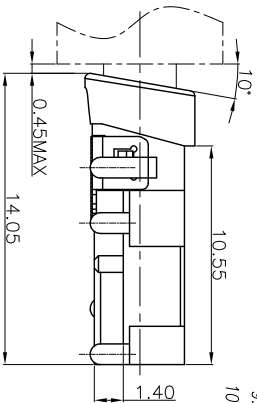

SPECIFICATIONS:

- ELECTRICAL CHARACTERISTICS:
 - RATING: 12V 1A
 - CONTACT RESISTANCE: 50mΩ MAX.(INITIAL)
 - DIELECTRIC WITHSTANDING VOLTAGE: 500V AC FOR ONE MINUTE.
 - INSULATION RESISTANCE: 100MΩ MIN. MEASURED BY 500V DC
- MECHANICAL CHARACTERISTICS:
 - INSERTION FORCE : 0.3~3.0 KGf
 - WITHDRAWAL FORCE : 0.3~2.0 KGf
- LIFE TEST: 5,000 CYCLES MIN.
- AFTER LIFE TEST, CONTACT RESISTANCE: 60mΩ MAX.
- AFTER HUMIDITY TEST, INSULATION RESISTANCE: 50MΩ MIN.
- OTHER GENERAL SPEC. TO REFER "
- "SINGATRON 02.5 03.5 PHONE JACK SPEC."
- TO CONFORM TO SINGATRON HAZARDOUS SUBSTANCE FREE SPEC.
- HALOGEN FREE PRODUCT IDENTIFICATION MARK ON PRODUCT: ©
- HALOGEN FREE PRODUCT IDENTIFICATION LOGO ON PACKAGING: ♻️
- FOR REFLOW SOLDERING LEAD-FREE PROCESS.

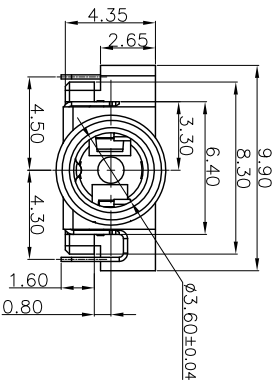
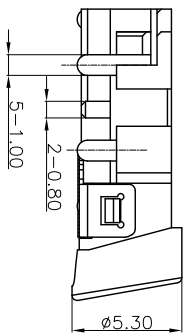
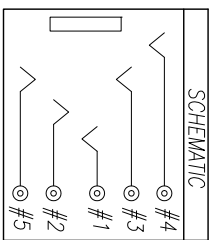
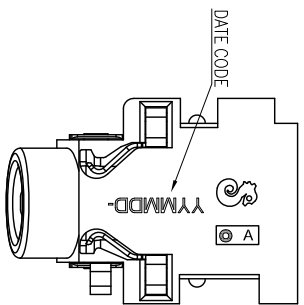
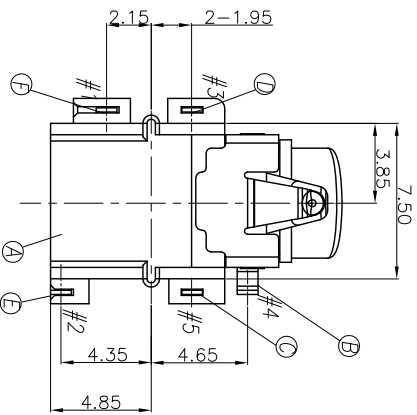
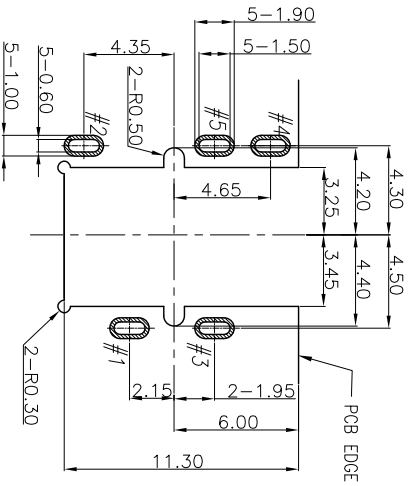

RECOMMENDED PCB LAYOUT(TOP VIEW)
(TOLERANCE: ±0.05)

NO	DESCRIPTION	QTY	MATERIAL	PLATING & COLOR
F	TIP SPRING	1	PHOSPHOR BRONZE 0.20T	
E	RING-A SPRING	1	PHOSPHOR BRONZE 0.2T	
D	R-RING-B SPRING	1	PHOSPHOR BRONZE 0.2T	SOLD FLASH ON CONTACT AREA. WHITE SN 120μ" ON SOLDER TAIL AREA
C	L-RING-B SPRING	1	PHOSPHOR BRONZE 0.2T	ALL OVER IN 50μ" PLATING.
B	EARTH SPRING	1	PHOSPHOR BRONZE 0.2T	
A	BODY	1	HIGH TEMP-THERMOPLASTIC UL 94V-0	BLACK

UNLESS OTHERWISE SPECIFIED TOLERANCES

DECIMALS: ANGLES:

X :±0.5 X :±2°
X.X :±0.3 X.X :±1°
X.XX :±0.2

Singatron Enterprise Co., Ltd.
信晉企業股份有限公司

Part No. 23S3035-031111F

Scale: 4:1 Unit: mm

Size: A3 Sheet: 1 of 1 Rev: A

CUSTOMER COPY