

REV.	ECN NO OR DESCRIPTION	REVISED	DATE
A	PDR NO: T111130-1A	Jie-Xiao	2012.04.27
B	ECN NO: S120748	Angus	2012.09.28

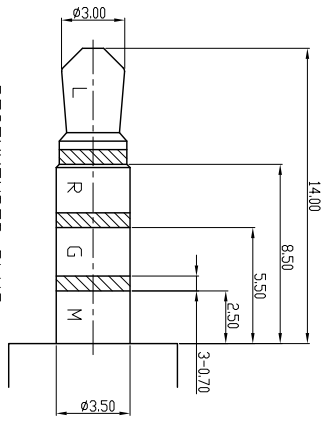

RECOMMENDED PLUG
4-POLE(±0.05)

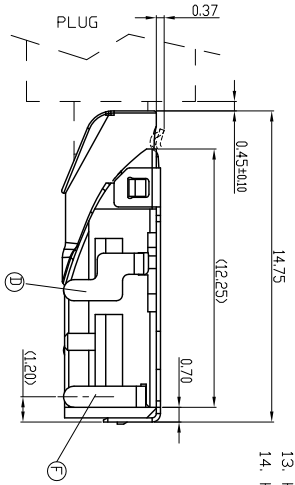
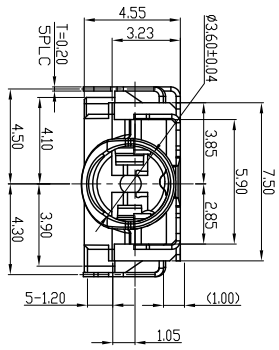
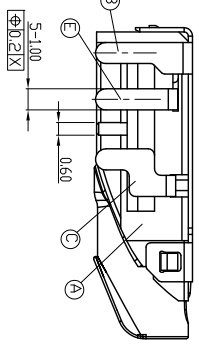
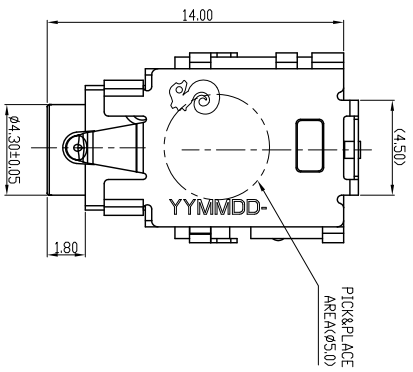

- SPECIFICATIONS:
- INSULATION RESISTANCE BETWEEN ANY ADJACENT OPEN CIRCUIT TERMINAL SHELL NOT BE LESS THAN 100MΩ
 - CONTACT RESISTANCE: 50mΩ MAX.
 - INSULATION VOLTAGE WITHSTAND:500V AC FOR ONE MINUTE.
 - UNLESS OTHERWISE SPECIFIED, TEST IS TO BE MADE AT 5-35°C IN TEMPERATURE AND 45-85% IN HUMIDITY. BUT,IF ANY VAGUE DATA IS OCCURED ON TEST RESULT, ANOTHER TEST SHALL BE MADE AT 20°C±2°C IN TEMP, 60-70% IN HUMIDITY.
 - LIFE TEST: 5,000 CYCLES MIN.
 - INSERTION FORCE: 0.3 - 3KGf.
 - WITHDRAWAL FORCE: 0.3 - 2KGf.
 - AFTER LIFE TEST, CONTACT RESISTANCE: 60mΩ MAX.
 - AFTER HUMIDITY TEST, INSULATION RESISTANCE: 50MΩ MIN.
 - MARKING: MARK * ON TOP OF CONNECTOR.
 - PACKING : TAPE & REEL.
 - TO CONFORM TO SINGATRION HAZARDOUS SUBSTANCE FREE SPEC.
 - HALOGEN FREE PRODUCT IDENTIFICATION MARK ON JACK
 - HALOGEN FREE PRODUCT IDENTIFICATION LABEL ON PACKAGING

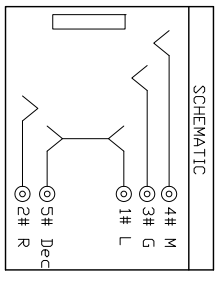
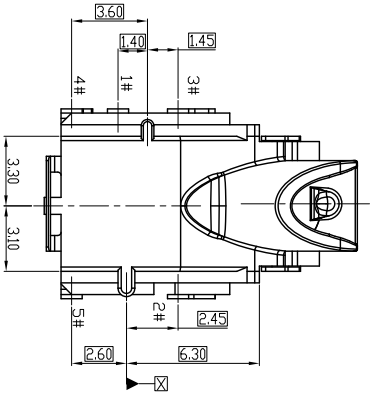
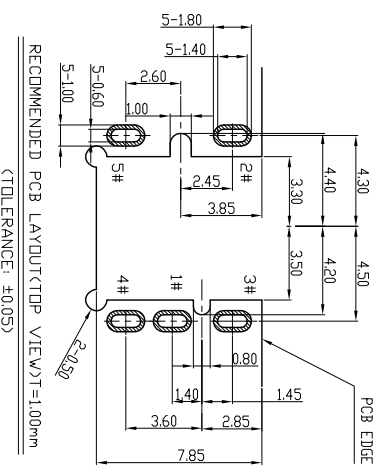

NO	DESCRIPTION	QTY	MATERIAL	PLATING & COLOR
F	TIP-B	1	PHOSPHOR BRONZE 0.2t	GOLD FLASH OVER 50μ NICKEL PLATING
E	TIP-A	1	PHOSPHOR BRONZE 0.2t	GOLD FLASH ON CONTACT AREA
D	RING-A	1	PHOSPHOR BRONZE 0.2t	MATE TIN 120μ SOLDER TAIL AREA
C	RING-B	1	PHOSPHOR BRONZE 0.2t	ALL OVER 50μ WICKET PLATING
B	EARTH	1	PHOSPHOR BRONZE 0.2t	IN 50μ MIN.
A	BODY	1	HIGH TEMP.THERMOPLASTIC UL 94V-0	BLACK

DECIMALS:	ANGLES:	TITLE
X : ±0.5	X : ±2°	Angus
X.X : ±0.3	X.X : ±1°	Tom
X.XX : ±0.2		Quan

UNLESS OTHERWISE SPECIFIED TOLERANCES:	Singatron Enterprise Co., Ltd.
	信音企業股份有限公司
	03.50 AUDIO JACK
	PART NO. 2SJ3059-012111F
	SCALE: 4:1
	UNIT: mm
	SIZE: A3
	SHEET: 1 OF 1
	REV: B

CUSTOMER COPY