

REV.	ECN NO OR DESCRIPTION	REVISED	DATE
A	PDR NO: T121213-5A	MARS	2013.04.17

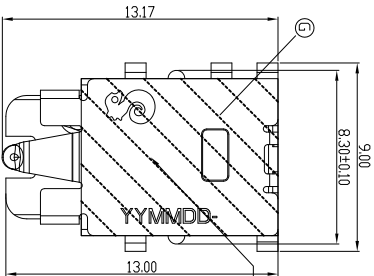

RECOMMENDED PLUG
4-POLE(±0.05)

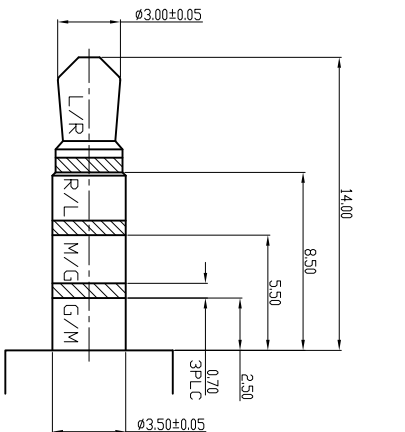
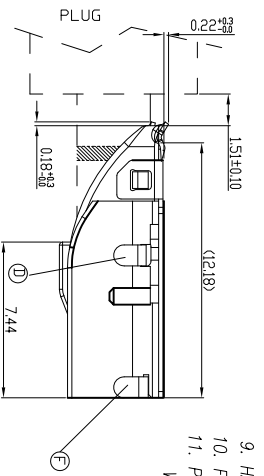
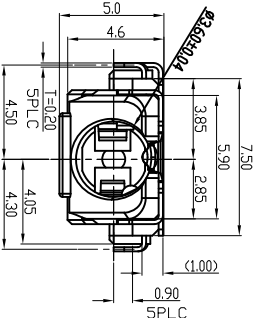
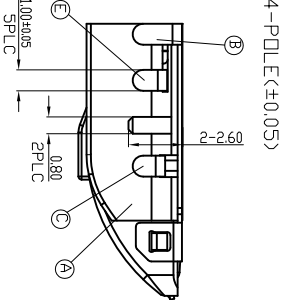

SPECIFICATIONS:

- ELECTRICAL CHARACTERISTICS:
 - 1-1. RATING: 12V 1A
 - 1-2. CONTACT RESISTANCE: 50mΩ MAX (INITIAL)
 - 1-3. DIELECTRIC WITHSTANDING VOLTAGE: 500V AC FOR ONE MINUTE.
 - 1-4. INSULATION RESISTANCE: 100MΩ MIN. MEASURED BY 500V DC
- MECHANICAL CHARACTERISTICS:
 - 2-1. INSERTION FORCE : 0.3~3.0 KGF
 - 2-2. WITHDRAWAL FORCE : 0.3~3.0 KGF
- LIFE TEST: 5,000 CYCLES MIN.
- AFTER LIFE TEST, CONTACT RESISTANCE: 60mΩ MAX.
- AFTER HUMIDITY TEST, INSULATION RESISTANCE: 50MΩ MIN.
- OTHER GENERAL SPEC. TO REFER "2SJ3059 SERIES SPEC."
- TO CONFORM TO SINGATRON HAZARDOUS SUBSTANCE FREE SPEC.
- HALOGEN FREE PRODUCT IDENTIFICATION MARK ON PRODUCT:
- HALOGEN FREE PRODUCT IDENTIFICATION LOGO ON PACKAGING:
- FOR REFLOW SOLDERING LEAD-FREE PROCESS.
- PLEASE PUT THE PRODUCT IN A CONDITION WHERE IS FULL OF NITROGEN WHEN PASS THE IR REFLOW

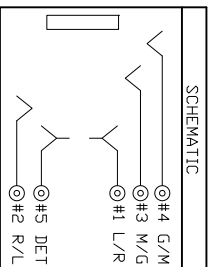
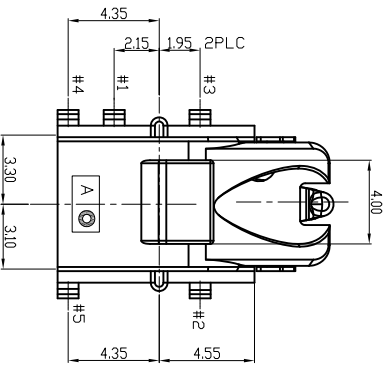
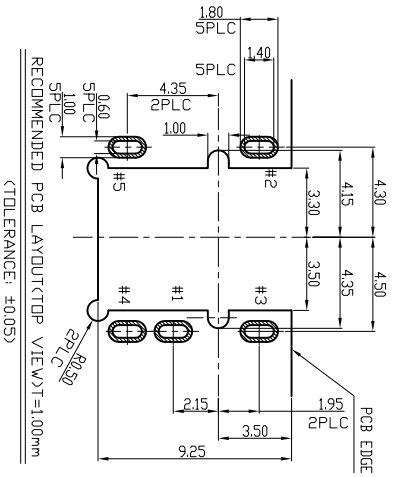

G	MYLAR	1	YELLOW	N/A
F	TIP-B	1	PHOSPHOR BRONZE 0.2t	GOLD FLASH OVER 50μ" NICKET PLATING.
E	TIP-A	1	PHOSPHOR BRONZE 0.2t	GOLD FLASH ON CONTACT AREA.
D	RING-A	1	PHOSPHOR BRONZE 0.2t	MATE TIN 120μ" SOLDER TAIL AREA.
C	RING-B	1	PHOSPHOR BRONZE 0.2t	ALL OVER 50μ" NICKET PLATING.
B	EARTH	1	PHOSPHOR BRONZE 0.2t	Ni 50μ" MIN.
A	BODY	1	HIGH TEMP.THERMOPLASTIC	BLACK COLOR
	DESCRIPTION	QTY	MATERIAL	PLATING & COLOR
		1	UL 94V-0	

UNLESS OTHERWISE SPECIFIED TOLERANCES

Singatron Enterprise Co., Ltd.
信晉企業股份有限公司

ø3.50 AUDIO JACK

DWN MARS PART NO. 2SJ3059-033111F

CHKD BRUCE SCALE:4:1 UNIT: mm

APVD LUSSEN SIZE: A3 SHEET: 1 OF 1 REV:A

CUSTOMER COPY